

July /29/2010



**FEIYU
TECH.**

FY 21AP VERSION II AFFS AUTOPILOT SYSTEM INSTALLATION & OPERATION MANUAL



Guilin Feiyu Electronic Technology Co., Ltd

Rm. B305, Innovation Building, Information Industry Park, Chaoyang Road, Qixing District,

Website: www.fyetech.com
Email: feiyudz@hotmail.com

Dear Pilot,

Thank you for purchasing the FY-21AP Version II stabilizer from FeiYu Tech.

In order to achieve full potential and safe operation of this product, please carefully read this manual prior to installation

Warning:

- The installation and use of this device require some skill and knowledge in flying remote controlled fixed wing aircraft.
- If you are a complete beginner and have never flown one before, we do not recommend you install this device on your own.
- Please find assistance from an experience flier who may provide you with the basic knowledge required to use this device successfully.
- If you are already an experienced flyer, you will find the installation to be easy and logical. Just follow the instructions as stated in this manual and you won't go wrong.

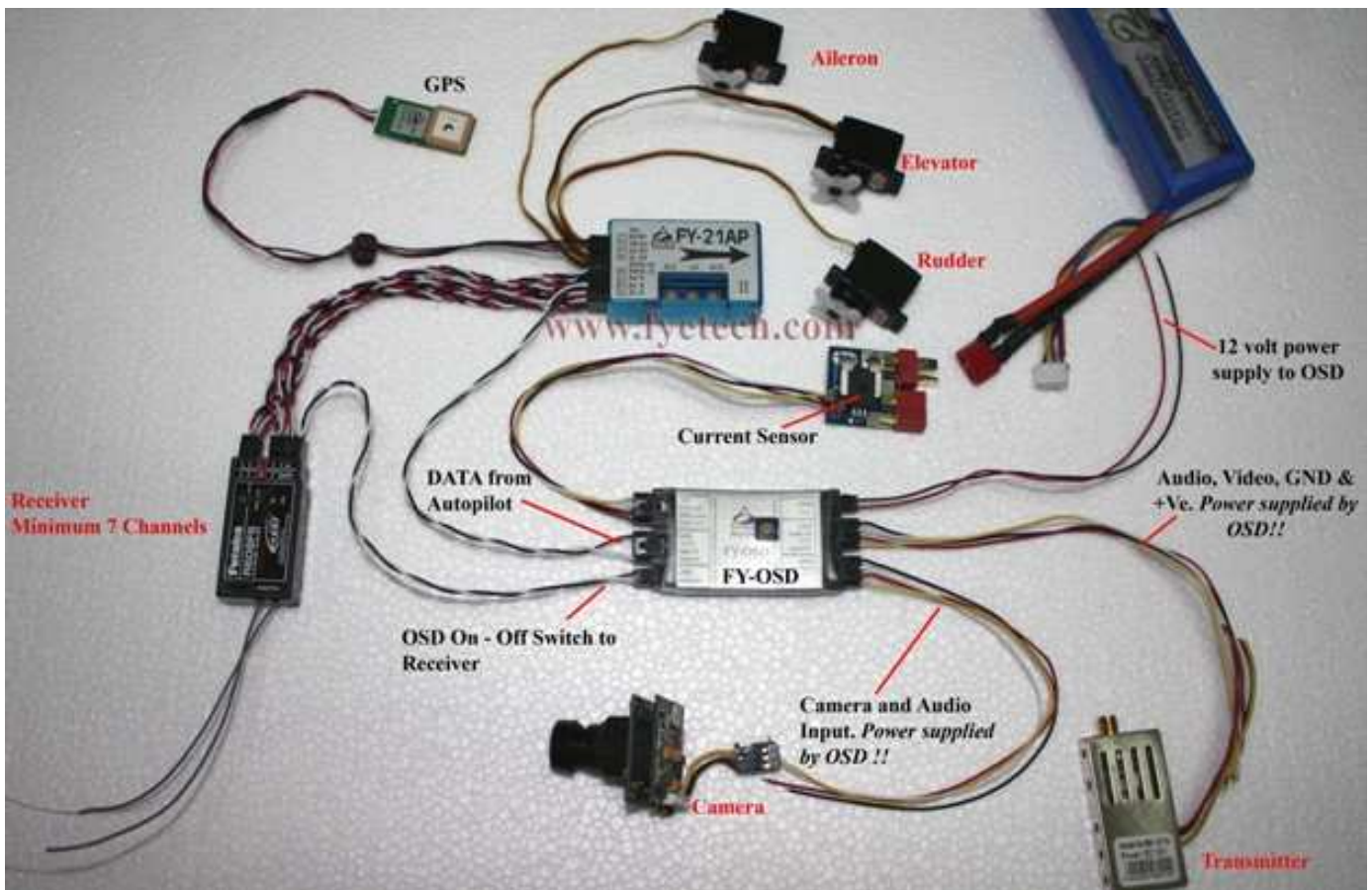

Table of Contents

How It Works	4
Attitude Flight Stabilization System (AFSS)	4
GPS, Barometric Sensing and Autopilot	4
DEVICE FUNCTIONS	5
FY-21AP Attitude Flight Stabilization System	5
FY-21AP GPS and Barometric Sensor	5
Optional Upgrade with FYOSD and 606 Data Radio	5
COMPLETE FY-21AP PACKAGE CONTENT	6
Technical Specification and working requirements:	6
Aircraft Suitability	6
Remote Control system requirement:	6
FY-21AP Flight Modes	7
□ MODE 1: Deactivated Mode	7
□ MODE 2: Stabilized mode	7
□ MODE 3: Fixed–Altitude Flight Mode	7
STALL WARNING	7
□ AUTOPILOT MODE 1: Deactivated	7
□ AUTOPILOT MODE 2: Auto Return to Launch (RTL)	7
□ AUTOPILOT MODE 3: Auto circling mode (ACM)	7
AUTOPILOT STALL WARNING	8
Gyroscope initialization (re-setting):	8
Initialization / Reset Process	8
FLIGHT INDICATOR (Red and Blue Light)	9
Red LED	9
Blue LED	9
The interface and features of the GPS circuit board	10
GPS – Satellite Signal Lost During Autonomous Flight	10
Schematic diagram of navigation control:	11
The Interface of FY-21AP	12

FY-21AP Electrical Connection and Diagram	13
Power supply	13
Connection to RC Receiver	13
SWITCH DEFAULT MODES	14
Switch IN1	14
Switch IN2	14
FLIGHT MODE SWITCH-IN1	14
FLIGHT MODE SWITCH-IN2 (AUTOPILOT MODE)	15
Plane Connection Layout:	17
Aileron-Elevator Mixing	17
Rudder-Elevator Mixing	17
VIBRATION	18
WARNING: VIBRATION CHECK	19
H. FY-21AP INSTALATION: ORIENTATION, POSITION & LEVEL	20
FY-21AP Pre-Flight Checking and Debugging	21
PRE-FLIGHT CHECK:	21
STEP 1: DIAL ADJUSTMENT	21
STEP 2: STABILIZED MODE	21
STEP 3: AILERON CHECK:	21
STEP 4: ELEVATOR CHECK	22
STEP 5: RUDDER CHECK	22
□ STEP 6: FLIGHT TEST AND SENSITIVITY ADJUSTMENT	23
WARNING: SAFETY PRECAUTION – MUST READ	24
FY-21AP INSTALLATION GUIDE	25

How It Works

Attitude Flight Stabilization System (AFSS)

FY-21AP Version II is an advance Attitude Flight Stabilization System (AFSS) and Autopilot for RC aircraft.

The FY-21AP utilizes a 3-axis gyroscope and tri-axial accelerometer to form an accurate drift free attitude stabilization system. The unit also utilizes Global Positioning System (GPS) and a barometric altitude sensing for accurate 3-dimensional positioning of the aircraft. By combining attitude control and positioning, a comprehensive inertial navigation system and autopilot is provided to you in a small compact light-weight package.

The AFSS achieves its attitude control via FeiYu Tech's proprietary algorithm; the unit calculates the aircraft attitude in 3-dimension and detects any changes to the model's horizontal position. If attitude change occurs, controlling signals will be sent out to the plane's ailerons, elevator and rudder to counter the change. By continuously doing this, the plane is kept in a state of stabilized equilibrium, resulting in a smooth level flight.

When activated, you only need to release the flight control sticks so that they return to the transmitter *neutral* (middle) position. The model will immediately revert to level flight. The unit can be activated or de-activated via a spare channel from your receiver.

GPS, Barometric Sensing and Autopilot

Upon initial boot up, the FY-21AP will search for GPS positioning signals. When a minimum of 5 satellites have been detected, a fixed position is established. The FY-21AP will record that position as the return to launch (RTL) point.

The on-board barometric sensor and GPS altitude readings will be combined to establish an accurate relative-altitude of the aircraft.

When the Autopilot Mode is activated via a spare channel, the aircraft will automatically turn and fly back to the take off point (RTL). The aircraft altitude will be constantly maintained. After reaching the home position, the plane will automatically circle with a radius of 120 meters. By using the same autopilot algorithm, you can also activate an auto circling flying pattern at a fixed altitude anywhere you wish.

DEVICE FUNCTIONS

FY-21AP Attitude Flight Stabilization System

- **Constant stabilized flight in any condition** – the FY-21AP will automatically level the flight attitude of your aircraft in any weather condition. If you are just learning to fly, this will help you gain experience, log more flying time and increase your confidence. The FY-21AP can be activated throughout the flight duration, from take off to landing.
- **Emergency Recovery** – in case you lose orientation or you feel the aircraft is out of control, activate the FY-21AP and let go of the control sticks. The FY-21AP will immediately bring the plane back to stabilized level flight.
- **Precision Flying**: For the experienced pilot, FY-21AP can help you achieve more leveled and precise flight paths, especially when flying and landing in strong wind.
- **First Person View (FPV)**: For long distance flying or FPV, the FY-21AP will take over the job of leveling and stabilizing the plane for you. Just point the plane where you want to go and enjoy the view!

FY-21AP GPS and Barometric Sensor

- **Fixed altitude flight** - When this function is activated, the unit will maintain your aircraft altitude. You only need to input the right throttle level and point the plane in the direction you want to go.
- **Return to Launch (RTL)** – You can flip the designated RTL switch on your radio and the aircraft will return to the take-off point. RTL can also be programmed into your Receiver failsafe so that the aircraft returns home if RC link is lost.
- **Fixed Position circling** – by activating this function, the aircraft will automatically circle the selected area at a fixed altitude. Very useful for aerial photography.

Optional Upgrade with FYOSD and 606 Data Radio

The FY-21AP provides an optional upgrade combining the FYOSD with the FY-606 Data Radio. With this add-on, you will receive:

- **Real time telemetry** – real time by-directional telemetry is monitored directly by your ground station computer. Changes to aircraft altitude, circle radius and flight path can be controlled from your ground station computer.
- **Record and monitor your flight** - you can monitor and download your flight path into your ground station computer.

For more information, please refer to the FY-OSD Version 2.0 and FY-606 manual.

COMPLETE FY-21AP PACKAGE CONTENT

In each set of FY-21AP, you will receive the following:

- 1 x FY-21AP Version II unit
- 6 x RC receiver connecting wire;
- 1 x GPS Receiver;
- 1 x Current Sensor;
- 1 x OSD circuit board;
- 2 x Velcro double sided tape
- 1 x instruction manual;
- 1 x vibration absorbing mount;
- GPS wire with ferrite filter
- Some related wiring



Technical Specification and working requirements:

Working voltage	: 4.0~6.0 Volt
Current draw	: 52mA (at 5V)
Size	: 55 x 33 x 20 mm(2.17 x 1.3 x .79 in)
Weight (exclude wire)	: 20g (0.71oz)
Working Temperature	: -25°C~ +70°C (-13°F~+150°F)
Maximum rate of rotating	: ≤ 1200 °/s

Aircraft Suitability

The FY-21AP has been proven to operate in the following aircraft:

1. Normal / Traditional fixed-wing planes
2. Delta-winged plane with rudder
3. Delta-winged plane without rudder,
4. Plane without aileron,
5. V –tail plane with aileron
6. V –tail plane without aileron
7. Any other configuration, please e-mail us for enquiry: feiyudz@hotmail.com

Remote Control system requirement:

The FY-21AP has been tested to work with the following RC systems:

- Robbe-Futaba PPM / PCM 1024 / PCM G3 mode, 2.4 GHz systems ;
- Graupner/JR PPM 8, PPM 12, SPCM mode ;
- MPX PPM8, PPM 12 with UNI mode
- Any remote control system using the standard of 1.5 ms *neutral position*.

FY-21AP Flight Modes

A. The FY-21AP has three flight modes. You may activate any of the flight modes via a free Receiver channel and a 3-position switch on your computer radio:

- **MODE 1: Deactivated Mode.** In this mode, all control of the aircraft is by the pilot. The FY-21AP does not participate in flight control.
- **MODE 2: Stabilized mode.** In this mode and your transmitter control sticks at center, the FY-21AP will continuously send out controlling signal (aileron, elevator, rudder) to ensure the aircraft maintains a stabilized, horizontal flight and constant flight direction. In this mode FY-21AP will not allow acrobatic flights.

Warning: The Auto Balance Mode will provide a smoother leveled landing for your aircraft. However, note that the turning radius is much larger when AFSS is activated. Please ensure your landing area has adequate clearance for this larger flight radius.

- **MODE 3: Fixed–Altitude Flight Mode.** In this mode the aircraft Stabilized Mode is activated combined with fixed altitude flight. Upon activation, the aircraft is immediately stabilized while altitude is maintained autonomously. You only need to control the direction of the plane.

STALL WARNING: The FY-21 AP has no control over your throttle channel. When flying in MODE 3, please ensure you have enough forward movement to prevent your aircraft from stalling. If your forward movement cannot compensate for the autopilot's active altitude hold action, your aircraft will stall.

B. FY-21AP Autonomous Flight Modes

Two autopilot modes are incorporated into the FY-21AP algorithm:

- **AUTOPILOT MODE 1: Deactivated.** The autopilot function is not activated.
- **AUTOPILOT MODE 2: Auto Return to Launch (RTL).** When activated in this mode, the FY-21AP will automatically fly the plane to the take-off point, while maintaining altitude. Upon reaching the launch area, the unit will automatically fly the plane in a circle at a default circling radius of 120 meters.

Note: Should you change the Autopilot Mode during lost of RC signal, the RTL Mode will immediately change to this latest mode upon RC signal **re-establishment**.

- **AUTOPILOT MODE 3: Auto circling mode (ACM).** When activated in this mode, the plane will immediately fly in a circle. The centre of the circle is the point of activation. The default circle radius is 120 meters. The aircraft altitude will be automatically maintained throughout the ACM.

AUTOPILOT STALL WARNING

- The FY-21AP has no control over the throttle channel. Therefore when flying in Autopilot Mode, please ensure you have enough forward movement to prevent stalling.
- If your forward movement cannot compensate for the autopilot's active altitude hold, your aircraft will stall.
- This is especially important if RTL is part of your RC failsafe. In the event of RC Link lost, you can set RTL into your Receiver failsafe. However, please do not forget to also set your throttle failsafe to between 25 % to 50% to prevent stalling.
- Never set your throttle failsafe to zero. If you do so, your aircraft will RTL in a continuous stalled flight which will result in a crash.

Gyroscope initialization (re-setting):

Out of the box, the FY-21AP has been fully initialized. However, if the following conditions occur, initialization is recommended:

- The device has not been used for a long time.
- There is a change in environmental temperature of over 30 degrees since last flight.
- When in **Mode 2: Stabilized Mode**, and the installed device in the horizontal position, the plane control surfaces begin to move and deflect by itself, without input from the pilot.

Initialization / Reset Process

Install the jumper as shown in this picture:

Power-ON the FY-21AP and keep it stationary for at least 20 seconds. You will notice the red light blink with two different rates.

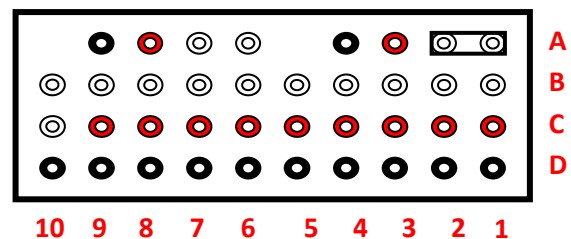

After 20 seconds the re-setting / initialization is complete. Disconnect the power, unplug the jumper & remove it (keep safe for future use).

NOTE: Carry out this re-setting procedure only if the above occur. **We do not recommend regular re-setting.** It is not necessary and not recommended.

The stabilizer unit does not need to be in a horizontal position during initialization. However, you must ensure there is no vibration during this process. If you suspect shaking occurred, just restart the initialization / resetting process.

FLIGHT INDICATOR (Red and Blue Light)

Red LED

The red LED indicator will light up when the FY-21AP is ON. The flight mode of your autopilot is indicated by how this LED flashes or stays solid.

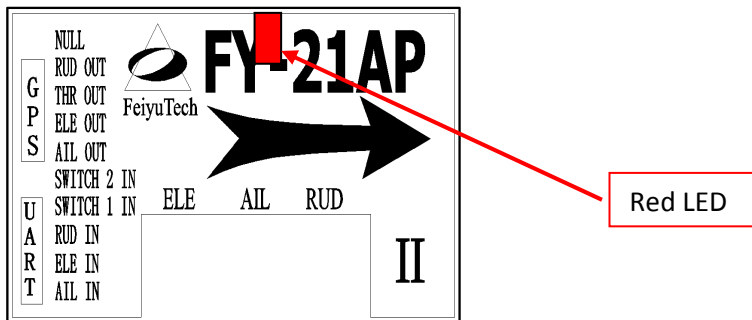

By observing this red LED, you can easily re-confirm your Flight Mode switch settings of your radio:

Flight mode	MODE 1: Stabilization <u>not</u> active	MODE 2: Stabilization active	Autopilot Mode 3: (circling mode)	Autopilot Mode 2: RTL	MODE 3: Fixed- Altitude Flight
Red LED light indicator	Continuous uniform flashing	Stay ON solid	Continuous, single flash each loop	Continuous, double flash each loop	Continuous flashing. 3 times each loop

Blue LED

The Blue LED light indicates the GPS status & vibration level experienced by the FY-21AP:

Status	Too much vibration (flight stabilization will not function)	No GPS	GPS data received	GPS location fixed (> 5 satellites)
Blue LED light Indicator	Stay ON solid	Stay OFF solid	Continuous Single flash each loop	Continuous double flash each loop

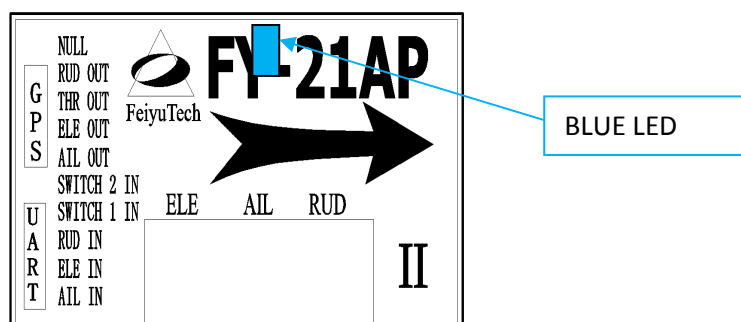

The interface and features of the GPS circuit board

TX0 : Data transmission. Connect to the FY-21AP RX pin.

RX0 : Data receive. Connect to FY-21AP TX pin.

Interface Features: TTL level

Baud rate: 38400

Data bits: 8

Stop bits: 1

Parity: None

GPS Data refresh rate: 10Hz

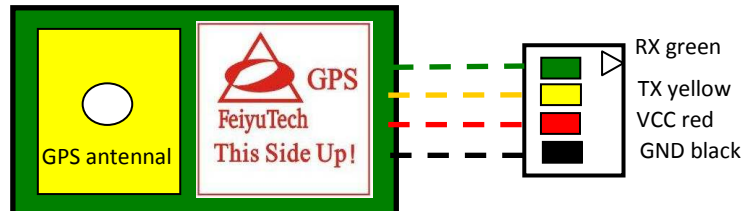

- If GPS cannot fix the aircraft location (minimum 5 satellites), only **Mode 1 (Deactivated)** and **Mode 2 (Stabilized Mode)** will function. Mode 3 and Autopilot will not be functional.
- Install the GPS Module with the antenna face up (see above). DO NOT install next to metal or carbon fiber and other shielding material, which may block satellite signal.
- Install the GPS Module away from electromagnetic sources such as ESC's, power wires, servo wires and video transmitters.

GPS – Satellite Signal Lost During Autonomous Flight

- GPS provides the aircraft geographic positioning, altitude, speed and flight direction.
- With this data the FY-21AP can perform the Autopilot Modes.
- In case GPS signal is lost during flight – e.g. in very cloudy weather - the autopilot will be switched off automatically. The FY-21AP will go into **Mode 3: Fixed Altitude Stabilized Flight Mode** until GPS position is regained.
- After GPS signal is regained the plane will resume the Autopilot Mode.

FY-21AP Version II - Schematic diagram of balance control:

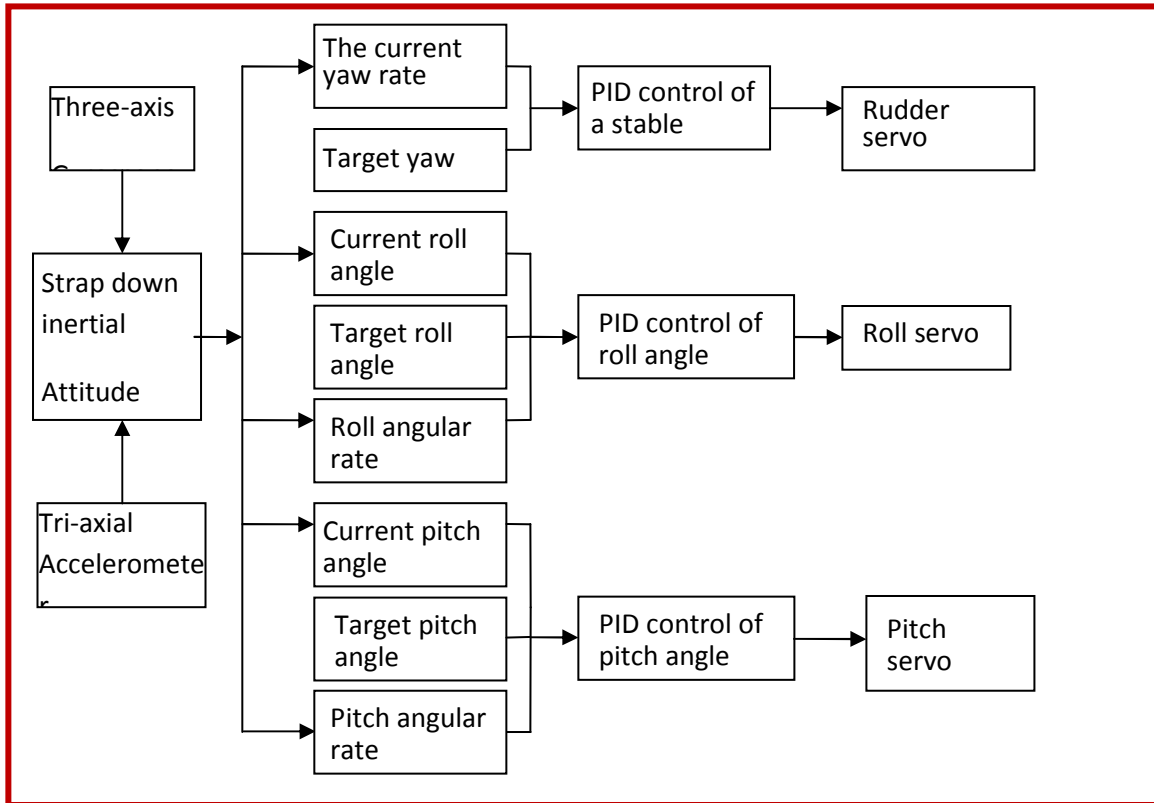

Schematic diagram of navigation control:

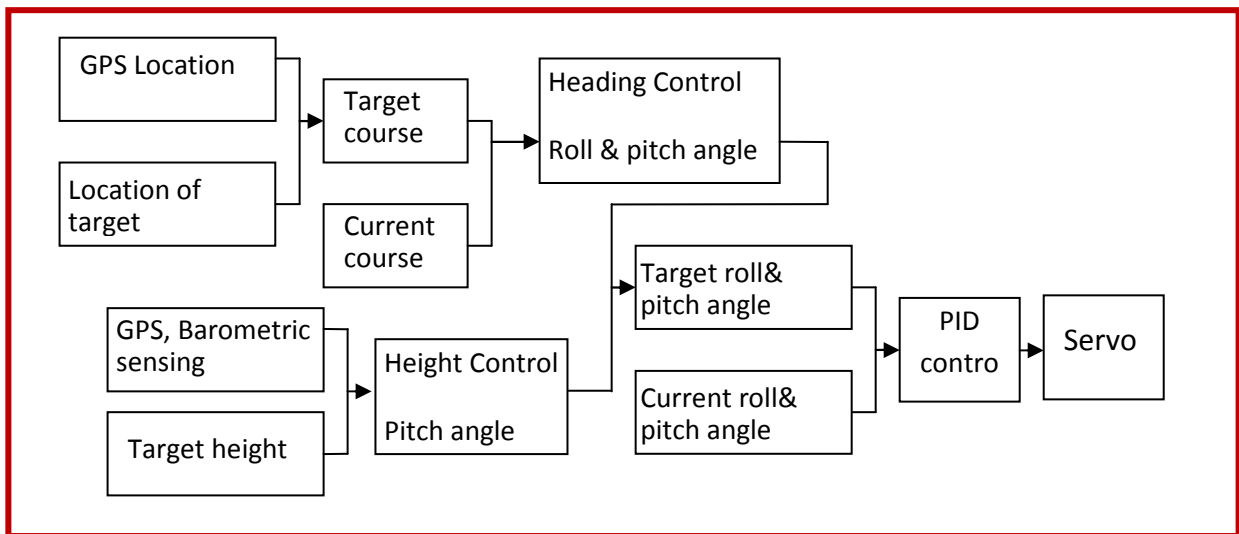

The Interface of FY-21AP

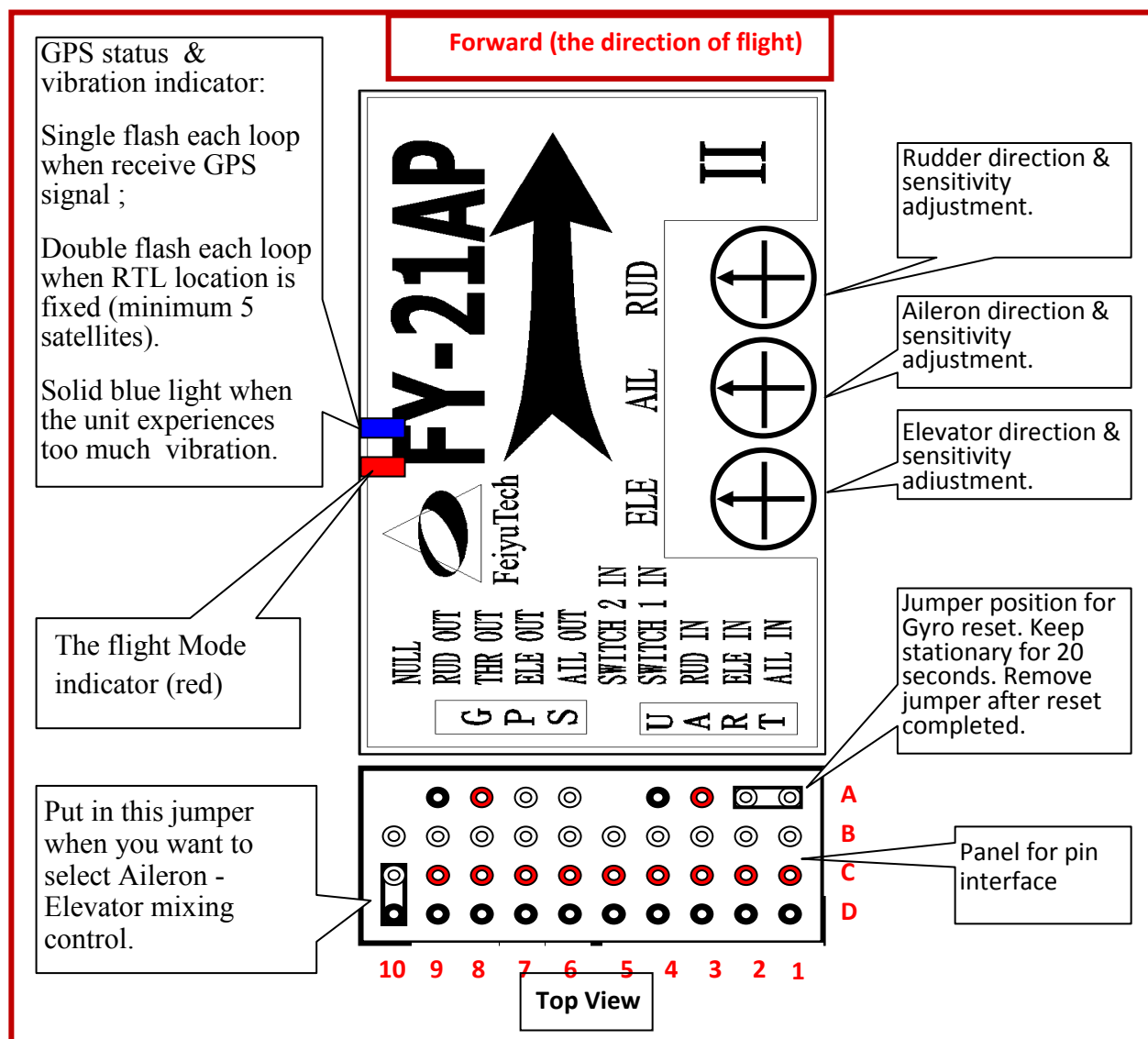

Panel for Pin Interface:

10	9	8	7	6	5	4	3	2	1	
Not used	GND	Power	TX0	RX0	Not used	GND	Power	TX1	RX1	A
Not used	Output to rudder servo	Signal output to throttle Out ①	Output to elevator servo	Output to aileron servo	Signal input for switch2	Signal input for Switch1	Signal input for rudder	Signal input for elevator	Signal input for aileron	B
Differential-Mode	Power	Power	Power	Power	Power	Power	Power	Power	Power	C
GND	GND	GND	GND	GND	GND	GND	GND	GND	GND	D

① Channel 8 is optional. It will output throttle control signal only if the FY-21AP is linked to the FY-606 Data Radio.

FY-21AP Electrical Connection and Diagram

Power supply

- The FY-21AP operates between 4 to 6 volts input.
- FY-21A is powered via the Receiver connection.
- If your plane is Electric powered, the Receiver power supply is normally from the ESC built-in Battery Elimination Circuit (BEC).
- Alternately, you can supply the Receiver and FY-21AP via a separate BEC.
- For Gas or Nitro powered planes, you will require a battery to power the Receiver and FY-21AP.

a) Connection between the FY-21AP and Receiver output is via the supplied wire:

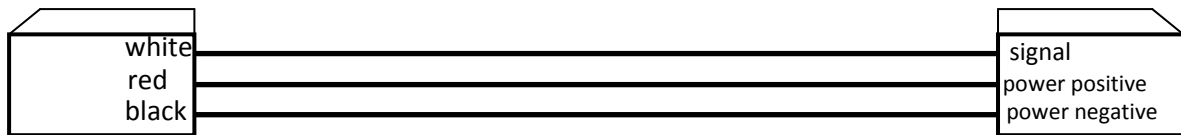

Connection to RC Receiver

- b) FY-21AP requires a minimum of 6-channel RC receiver.
- c) 3 Receiver channels are used for aileron, elevator and rudder signal output. Connect this 3 receiver output signals to the FY-21AP with the supplied wires.
- d) 2 free Receiver channels are required to control the FY-21AP Flight Modes (3-position switch) and Autopilot Mode (3-position switch).
- e) Example of 6 channel receiver utilization (refer page 11):

Channel 1 = Aileron Signal Output

Channel 2 = Elevator Signal Output

Channel 3 = Throttle Signal Output

Channel 4 = Rudder Signal Output,

Channel 5 = Switch IN1 controlled by radio 3-position switch for FY-21AP Flight Modes.

Channel 6 = Switch IN2 controlled by radio 3-position switch for FY21AP Autopilot Modes.

ATTENTION: The FY-21AP does not have Differential-Mode stabilization for rudder-elevator mix. Therefore, the rudder-elevator differential control for V-tailed planes must have an add-on mixing device for the corresponding differential channel before connection to the servos.

SWITCH DEFAULT MODES

Switch IN1

- If the FY-21AP does not detect any incoming signal to the **Switch IN1** Channel Input, it will automatically engage **Mode2: Stabilized Mode**.
- However, we DO NOT recommend flying the unit with no signal input to the FY21AP Switch Channel. It is possible that the auto balance will not function properly if the Switch channel is left open.
- If you do not have a 3 position switch available on your radio, you can set the flight Modes using a two position switch. However you need to omit one of the flight modes. For example, you may choose to set Mode 1 (Stabilization Deactivated) and Mode 3: (Fixed Altitude Flight Mode) on your two-position switch, therefore omitting Mode 2 (stabilized flight).

Switch IN2

- If the FY-21AP does not detect any incoming signal to **Switch IN2** Channel Input, it will automatically engage Autopilot Mode 1: Deactivated (no autopilot).
- However, we DO NOT recommend flying the unit with no signal input to **Switch IN2** Channel. It is possible that the autopilot will not function properly if the Switch channel is left open.
- If you do not have a 3 position switch available on your radio for Switch IN2, you can set the Autopilot Modes using a two position switch. However, you will only have two working modes: Autopilot Mode 1 (Deactivated) and Autopilot Mode 3 (Auto circling).

FLIGHT MODE SWITCH-IN1

- To select the modes, set your End Points Adjustment (EPA) for the 3-Position Switch:

Switch-IN1 Signal input	900-1200 μ S	1200-1800 μ S	1800-2100 μ S
Functional Mode	Deactivated	Stabilized Flight Mode	Fixed Altitude Flight Mode

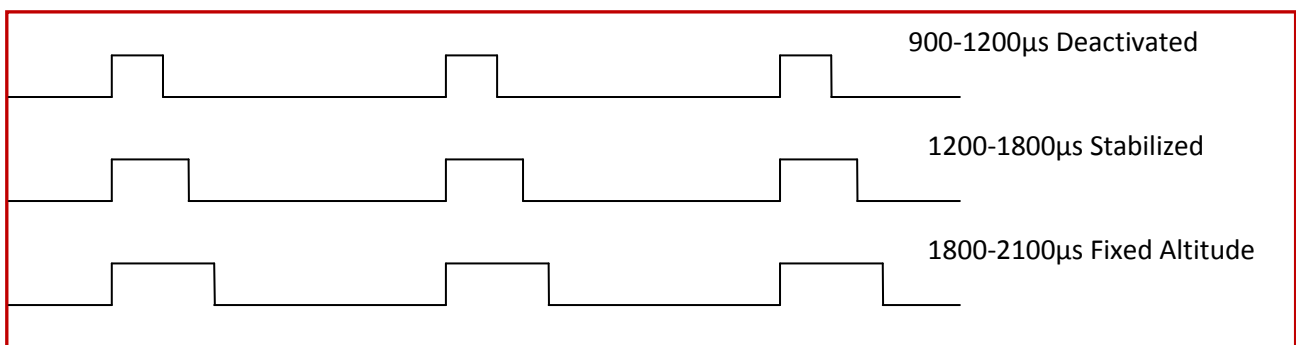

FLIGHT MODE SWITCH-IN2 (AUTOPILOT MODE)

- FY-21AP needs one free channel from your receiver to control the Autopilot Modes.
- Connect this channel to “SWITCH_IN2” of the FY-21AP stabilizer.
- **IMPORTANT:** Activation of the Autopilot Modes (RTL and Auto Circling) has priority over the 3 flight stabilization modes controlled by SWITCH-IN1. If you wish to use the Flight Mode controlled by Switch IN1, you must de-activate the Autopilot Modes via Switch IN2 first.

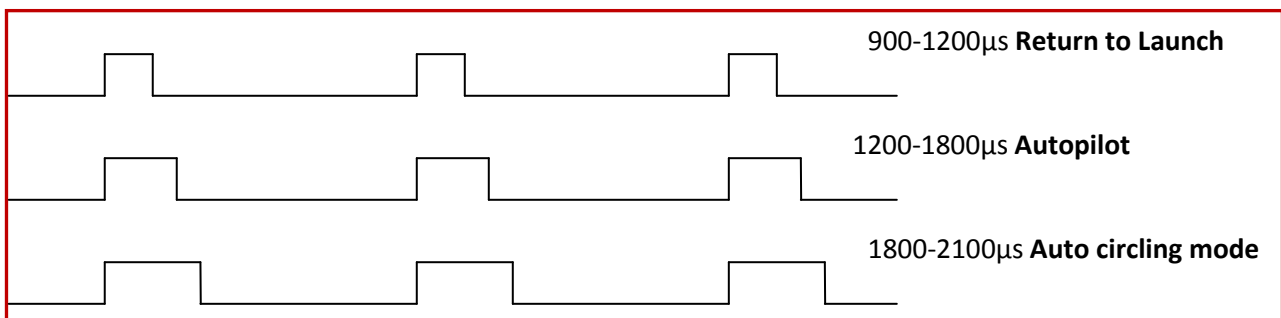

Switch-IN2 Signal Input	900-1200µs	1200-1800µs	1800-2100µs
Function Mode	Return to Launch (RTL)	Autopilot Deactivated	Auto circling mode (ACM)

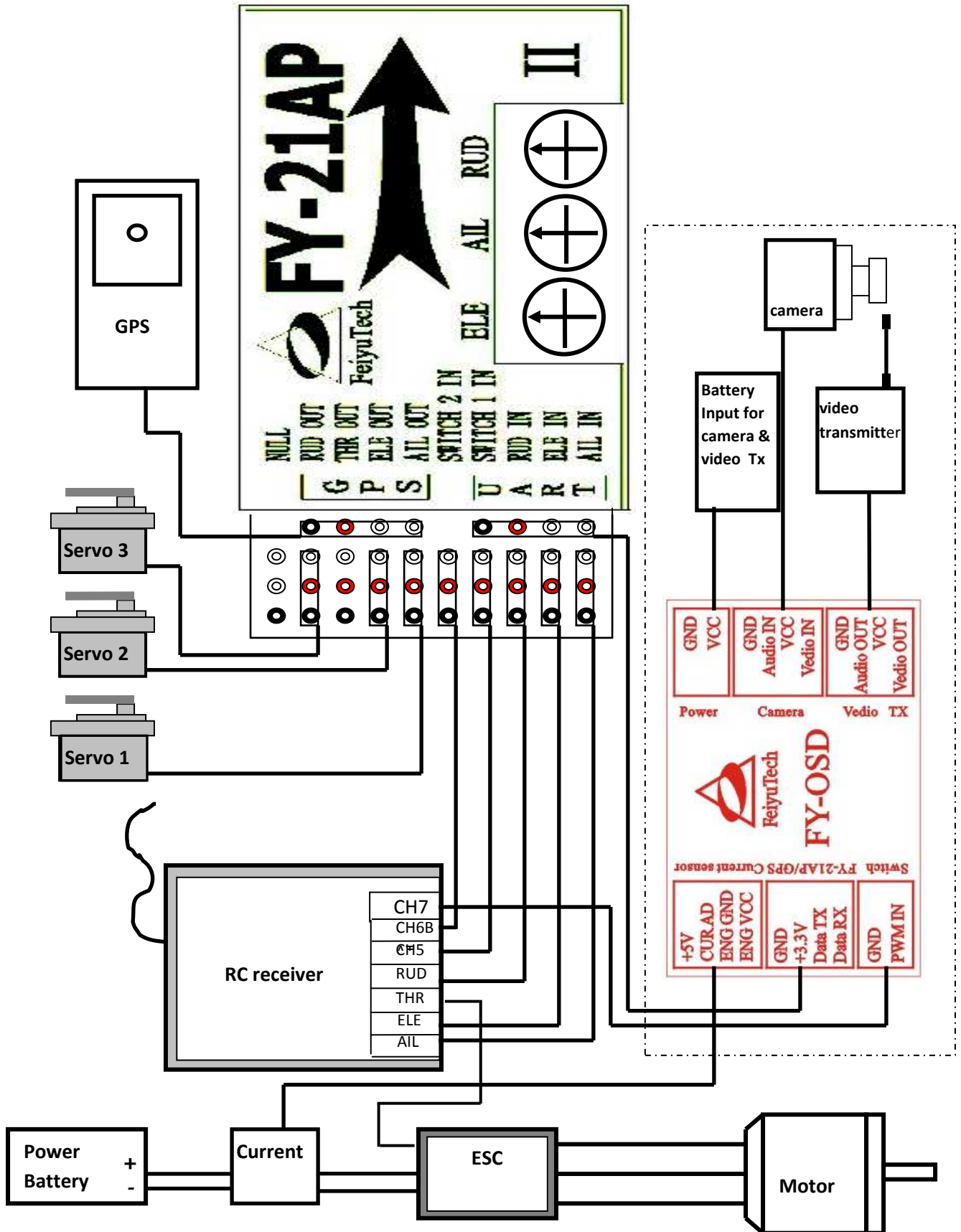



Plane Connection Layout:

Normal / Traditional servo layout:

Servo 1	Servo 2	Servo 3
Aileron servo	Elevator servo	Rudder servo

Plane without aileron servo:

Servo 1	Servo 2	Servo 3
Rudder servo	Elevator servo	Don't connect

Delta-winged plane servo:

Servo 1	Servo 2	Servo 3
Differential servo 1	Differential servo 2	Rudder servo

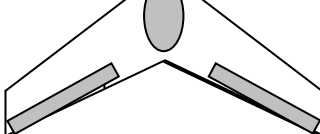

For all fix wing aircrafts (including the traditional rudder, aileron and elevator planes, and planes with aileron and elevator mixing, and so on, if the rudder is NOT used in any mixing function, you can:

1. Keep the FY21AP rudder channel (RUD IN, RUD OUT) open (not used). Connect the Rudder servo directly to your RC Receiver. Autopilot can still work normally; eg.auto circling and RTH.
2. Connect your Receiver Channel 4 to FY21AP (RUD IN) and connect the rudder servo to RUD OUT.

Aileron-Elevator Mixing

For the following aircraft: Delta Wing with Elevator signal mixing (e.g. Flying wing elevon):

Differential Output is carried out by using a jumper as shown here. The jumper has to be installed before powering ON. If you install it after powering ON, the mixing function will not take effect.

Do not remove this jumper. Leave it installed as long as you are using the mixing function.

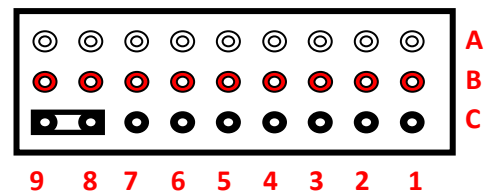

Rudder-Elevator Mixing

The Jumper should NOT BE USED if you want to do Rudder-Elevator Mixing, because FY-21AP does not support Differential-Mode stabilization for rudder-elevator mixing.

Therefore, the rudder-elevator differential control for V-tailed planes must have an add-on mixing device for the corresponding differential channel before connection to the servos:

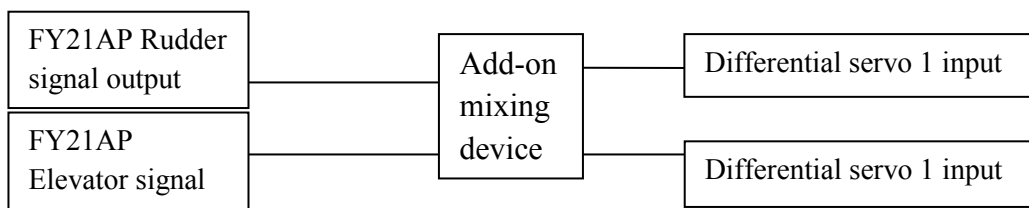

VIBRATION

- a) The AFSS in the FY-21AP is vibration-sensitive. To optimize its stabilization capability, vibrations reaching the unit must be kept at a minimum.
- b) Therefore when installing this flight stabilizer, we highly recommend that you install it with the supplied shock absorbing platform.
- c) The algorithm in the FY-21AP compensates from normal levels of flight vibrations. However, if the vibration experienced by the unit exceeds the acceptable level, it may not work normally or may even stop working altogether.
- d) To keep vibration at a minimum, install the FY-21AP away from the engine or any other vibration sources.
- e) The included vibration-absorbing mount will meet the damping requirements of electric powered aircrafts and most gas / nitro planes.
- f) If you receive your shock absorbing mount uninstalled (A), please complete it as shown below (B):

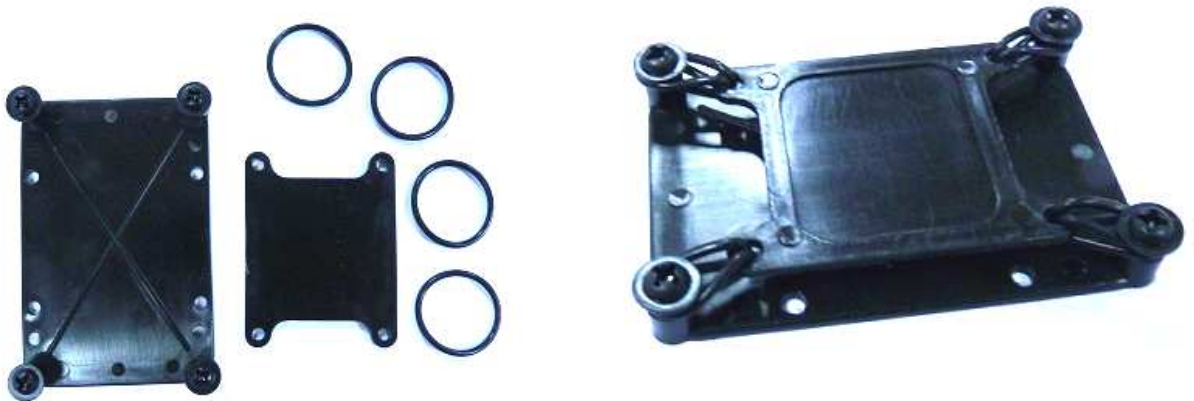

- g) Use the supplied Velcro strips to mount the FY-21AP to the suspended platform (below).
- h) Mount the entire unit to the plane using double sided tape (recommended), Velcro, screws or glue.

Stick the FY-21AP on the shock absorbing mount



WARNING: VIBRATION CHECK

Even with the shock absorbing mount, your aircraft installation may not meet the damping requirements of the AFSS. To confirm correct vibration damping:

- A. Connect all wires between the Receiver, FY-21AP and Servos, install the unit as recommended (ensure correct orientation).
- B. Run the plane engine or motor at different throttle levels. **DO NOT TAKE OFF.**
- C. Move the throttle level at different positions & maintain for 20 seconds at each level.
- D. At each throttle position, observe the state of the red and blue lights.
- E. If the blue lights stay ON solid then the vibration dampening is not enough.
- F. If the blue light does not stay ON solid, this indicates the vibration dampening requirements have been met.
- G. Please note that the blue light is also an indicator of GPS connection. However, the blue LED takes priority to indicate vibration status first, then the GPS connection.

H. FY-21AP INSTALATION: ORIENTATION, POSITION & LEVEL

- i. The FY-21AP has an arrow printed on the top of it. Orientate the arrow towards the front of the craft (i.e. direction of flight).
- ii. When installing, please keep the FY-21AP horizontal and as close as possible to the "Centre of gravity" (CG) of the aircraft.
- iii. The control benchmark of FY-21AP is its horizontal position. Therefore, ensure the FY-21AP is in the horizontal position when the plane is in level flight.
- iv. If there is deviation between the FY-21AP horizontal position and the plane's level flight, it may cause the neutral value to be different between Mode 1 (Deactivated) and the stabilized Flight Modes. This difference may result in the following:

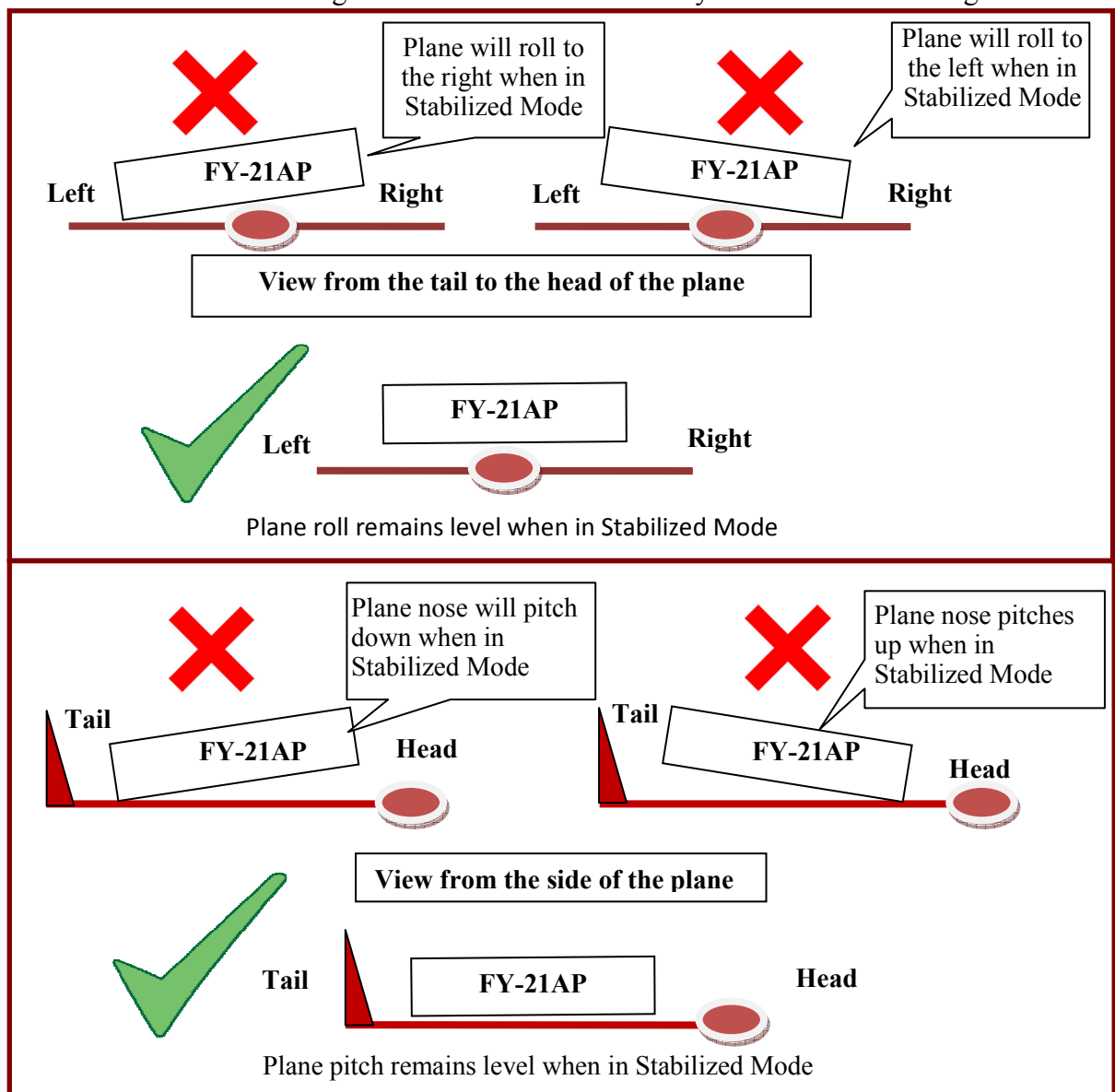

- v. We do not recommend using your transmitter trims to level your aircraft in Auto Balance mode, as the new trim settings will affect your aircraft when you revert to Manual Mode. It is best to land and adjust the FY-21AP installation.

FY-21AP Pre-Flight Checking and Debugging

PRE-FLIGHT CHECK:

The following procedure explains how to check for correct servo control direction upon FY-21AP activation. You should also check that the FY-21AP does not control the aircraft servos when in Mode 1: Deactivated Mode.

STEP 1: DIAL ADJUSTMENT

Adjust the three dials on the FY-21AP so that the arrow is in the middle, as shown below. Then rotate all dials in one direction (does not matter which direction):

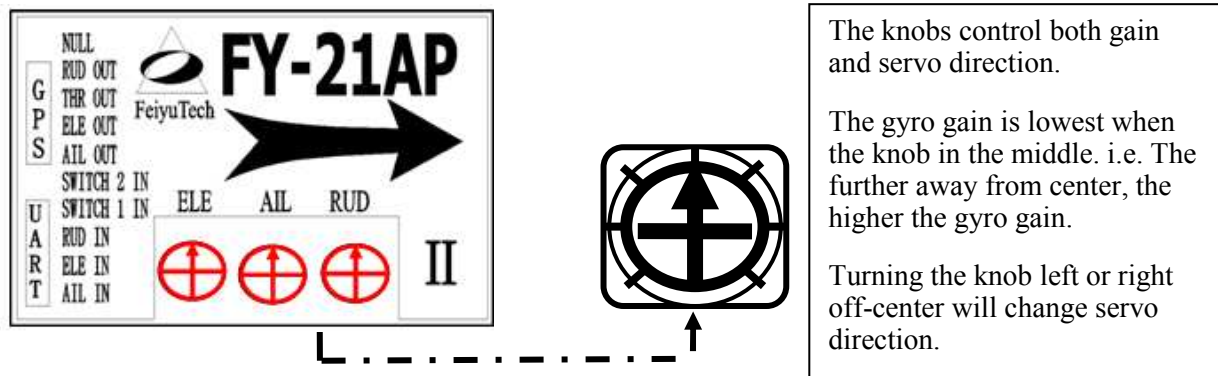

STEP 2: STABILIZED MODE

Place the plane on a horizontal surface with both the wings and pitch leveled. Centre the rudder surface. Move your radio 3-position switch so that the FY-21A is in **Mode2: Stabilized Mode**.

STEP 3: AILERON CHECK:

- Incline the plane to the right (roll right). The ailerons should give a control signal to counter this roll direction (see below). Same as when rolled to the right. If the ailerons move correctly, the knob has been turned in the right direction. You can now adjust gain by moving nearer (low gain) or further away (high gain) from center:

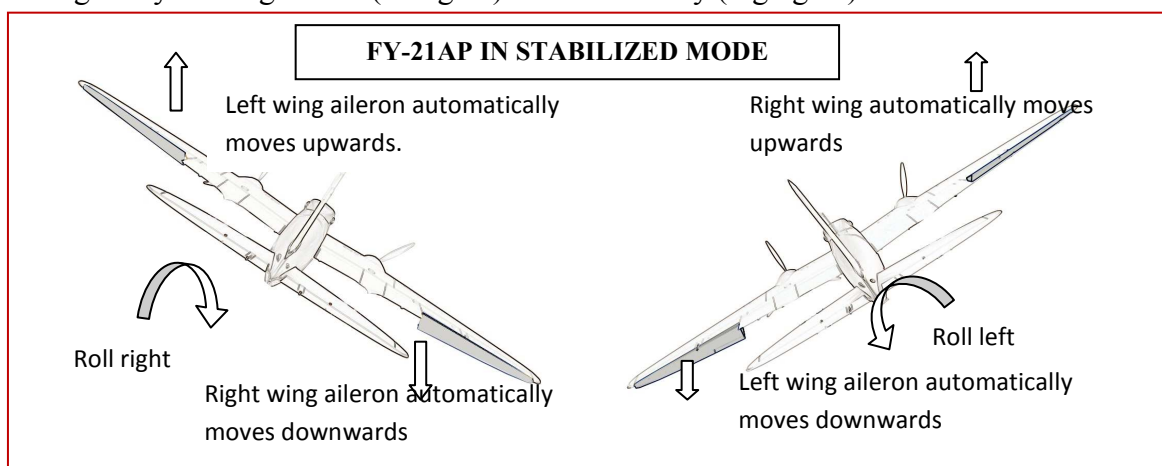

- If the ailerons do not follow the movements shown above, simply turn the aileron knob to the opposite side (beyond centre). You should now see the correct aileron movement.

STEP 4: ELEVATOR CHECK

- Incline the plane NOSE UP. You should see the elevator move down. And when you move the NOSE DOWN, the elevator should move up. Move the Elevator knob to the opposite side (from Centre) if the servo movement is incorrect:

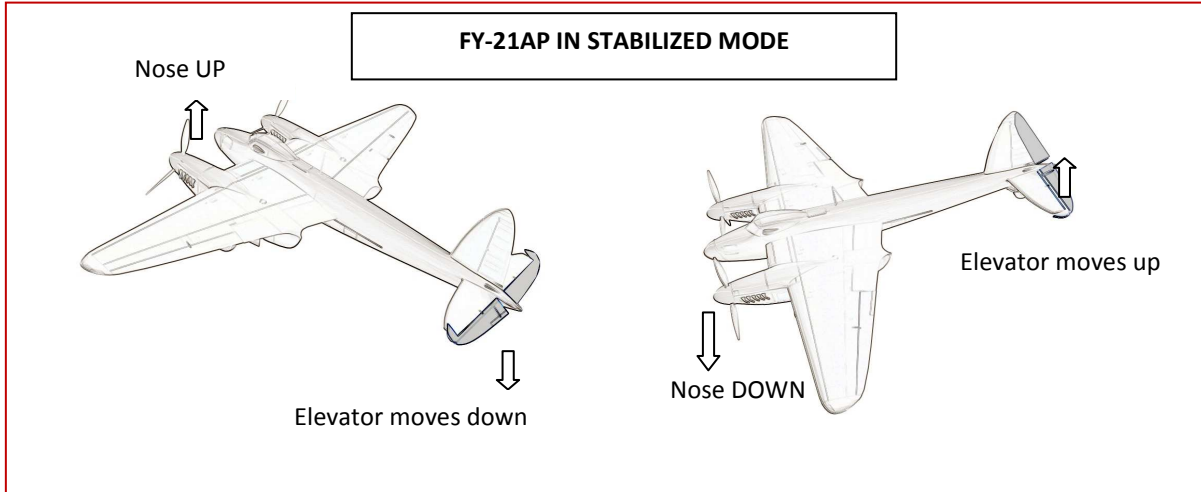

- Adjust Elevator gain according to your aircraft requirement (lowest gain nearest to centre, highest gain further away from centre).

STEP 5: RUDDER CHECK

- Rotate the plane at its centre axis from left to right. You should see the following action:

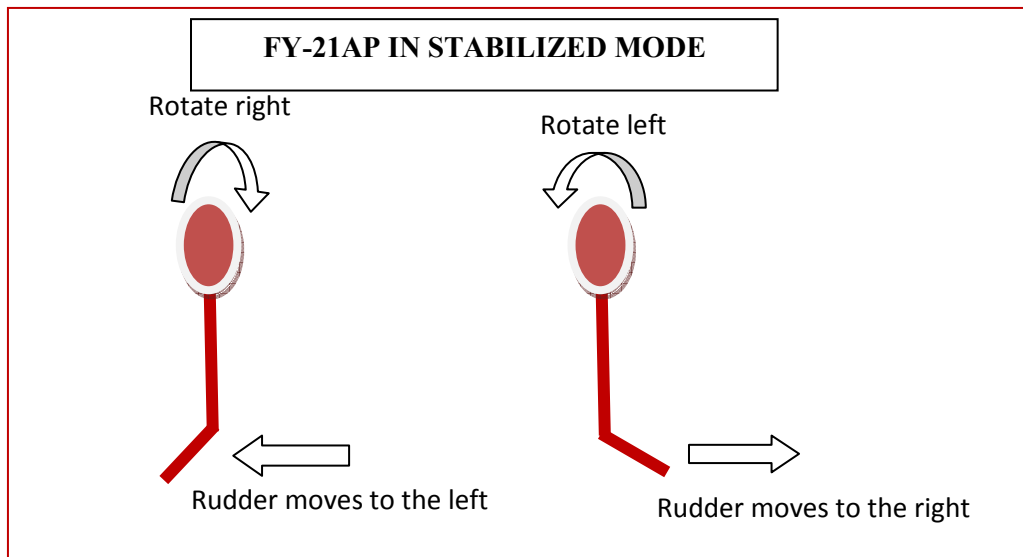

- Move the Rudder knob to the opposite side (from Centre) if the servo movement is incorrect:
- Adjust Rudder gain according to your aircraft requirement (lowest gain nearest to centre, highest gain further away from centre).

STEP 6: FLIGHT TEST AND SENSITIVITY ADJUSTMENT

- Steps 1 to 5 should enable you to correctly set your servo movement direction via the 3 knob dials.
- To fine tune your aircraft attitude control via the FY-21AP, some flight testing has to be performed.
- For the first flight it is recommended that the gains not be set too high. This will reduce large oscillation or 'flight overcorrection'.
- After the flight take off, switch the device from Mode 1 (deactivated) to Mode 2 (Stabilized mode).
- If you see oscillation of the wings, this indicates the Aileron gain is set too high. Switch back to Mode 1 (deactivated) and land the airplane.
- Reduce the sensitivity (move dial towards centre position) and fly again. You should see improvement in wing attitude. Adjust until you are satisfied with the level of wing stabilization.
- Too much Elevator gain will show the tail moving up and down (rocking). Too much Rudder gain will show tail wagging. Reduce gain until this flight overcorrection is gone.
- Alternately, if you find the flight correction is not enough, you can increase gain accordingly.

WARNING: SAFETY PRECAUTION – MUST READ

- I. The purpose of the FY-21AP (AFSS) is to stabilize the aircraft. It is not an Anti-Stall device. The stabilization action of the FY-21AP will fail if the aircraft is stalled. Please ensure adequate throttle especially when in the Autopilot Modes.
- II. The aircraft direction is controlled by you, at all times. Make sure you know where you are going.
- III. The FY-21AP is for your enjoyment. But do not fly the plane into a crowded area, where your aircraft can cause serious injury if it crash. Please be responsible when using this product.
- IV. Besides the regular pre-flight checks (we recommend a checklist). Always check the correct operation of the stabilizer on the ground prior to take off.
- V. Any electronic and hardware on an RC aircraft can fail over time. Please assess your aircraft and electronic condition before use. FeiYu Tech is not responsible for any losses or injury as a consequence of using this product.
- VI. Please ask an experienced RC Plane pilot for assistance if you are a beginner. It is absolutely critical that you get flight basics before proceeding. You also need directions to correctly assemble, take off and control your RC Model. We highly recommend joining your local RC Model club.
- VII. Never fly close to people, buildings, overhead wires, vehicles, trees or closed spaces. You could seriously injure yourself or someone else.
- VIII. Minimum flying distance should be 20 foot from you and others. Learn about emergency procedures should you lose control of your aircraft.
- IX. Keep the RC Model and related equipment away from children. RC planes are not toys. Children must be supervised at all times if they are allowed to fly.
- X. Please operate your RC plane within the permitted area of your local government. For more detail, please check with your local council or government.
- XI. If you are not using 2.4 GHz spread spectrum radio, never turn on your radio before checking and re-checking that you're the only one using the frequency. You could cause a crash of another aircraft if the frequency is the same. For security; please obey to the local frequency regulation.
- XII. Never use the remote control within three miles of your local airport. You could endanger full scale aircraft instruments. Lives could be lost.
- XIII. Keep all electrical equipment away from rain water, moisture and extreme high temperature.

FY-21AP INSTALLATION GUIDE

Equipments list:

- FY-21AP;
- FYOSD;
- FY-CS100A;
- FUTABA remote controller;
- FUTABA10 receiver;
- video transmitter;
- A pair of scissors,
- A knife;
- Double sided tape;
- Battery;
- Aircraft;
- Some related wirings.



1. Prepare the plane, install the electrical motor, servo, etc.



2. Aircraft installation tools may include (but not limited to) screwdriver, scissors, knife, foam double-sided tape, Velcro with double sided tape, etc



3. You should be able to do some basic wire soldering to install the FY-CS100A (main battery current sensor).
Connection wires include FYOSD plug, connecting wires for camera and video transmitter to FYOSD, the data wires between FYOSD to the FY-21AP and the connecting wires from FYOSD to the RC receiver.

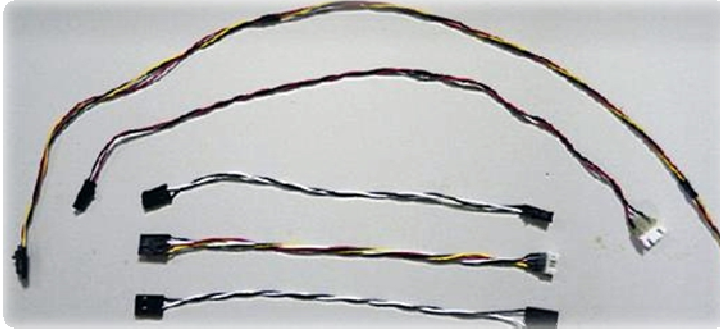

4. FYOSD connection to camera and Video Transmitter.

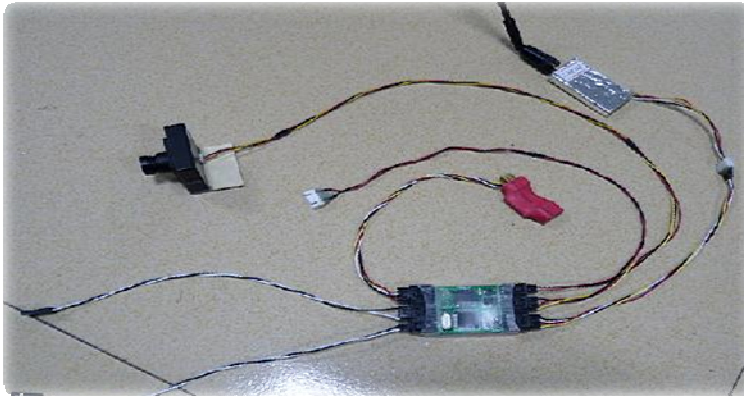

5. We recommend making a hatch door for FY-21AP installation:.



6. Connect the extension wire of the video transmitter. Install video transmitter to fuselage.



7. Connecting wires for FYOSD.

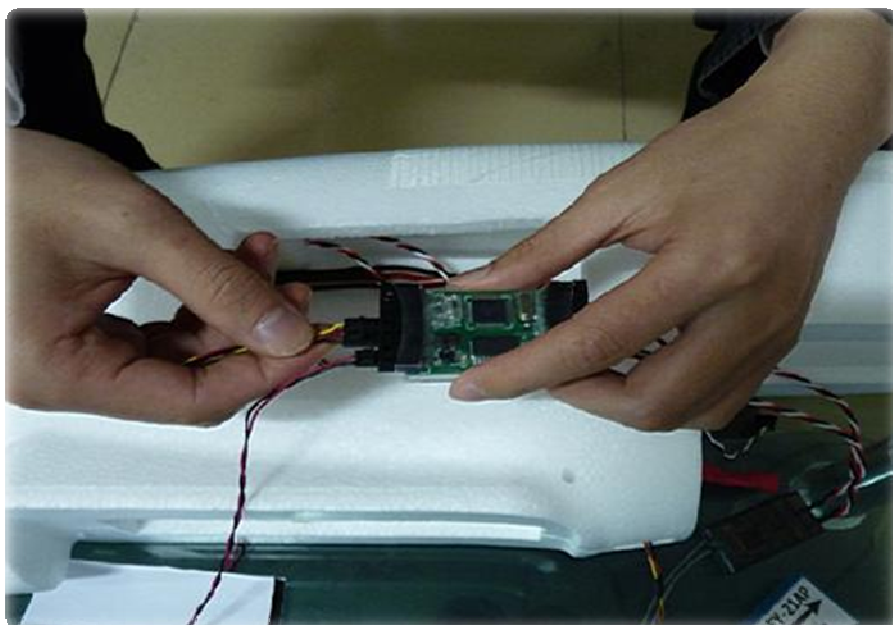

8. Use the Velcro tape to install FYOSD to the aircraft cabin.

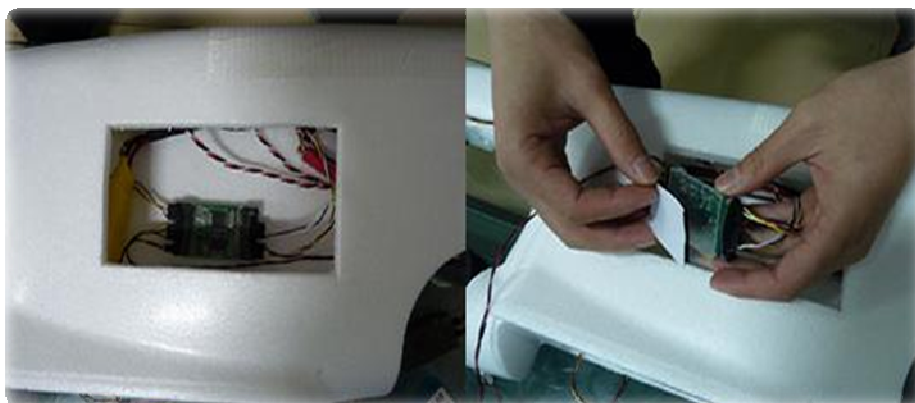

9. Connect the RC receiver to the FY-21AP.

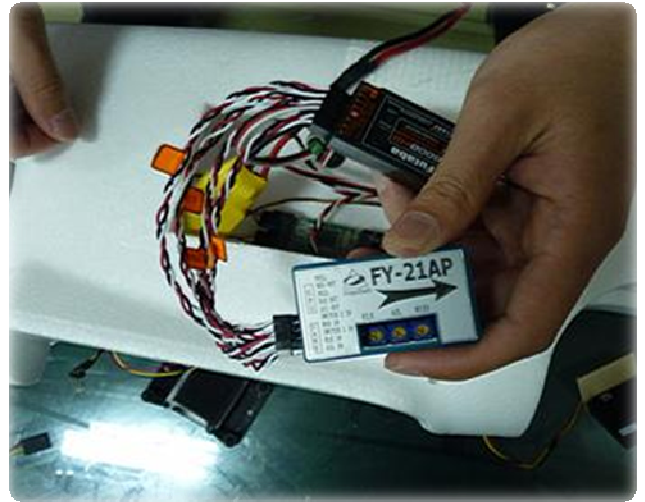

Connect the servos to the FY-21AP.

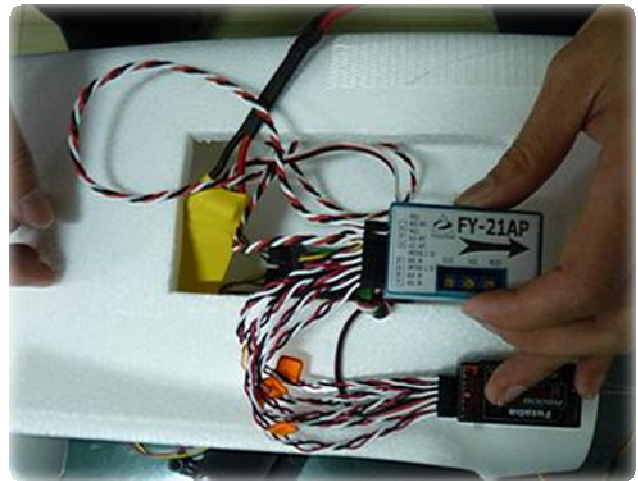

10. Power ON and check the connecting wires. Move the control sticks and check for correct rudder, aileron and elevator movement.

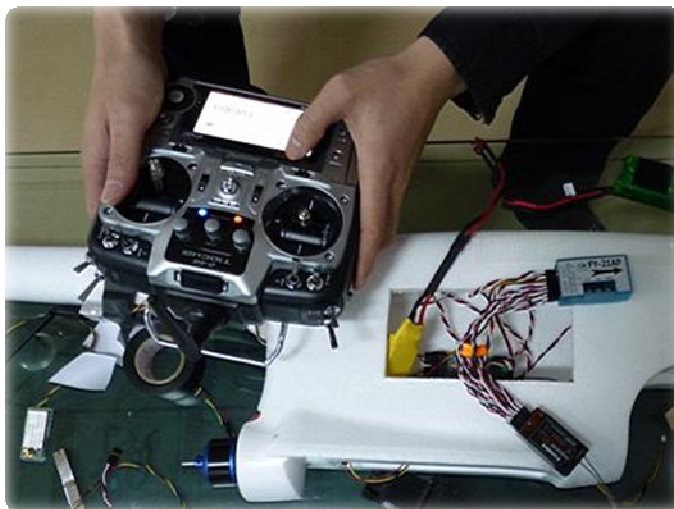

11. Set CH5 and CH6 to a 3-position switch to control the three Flight Modes and Autopilot Modes of the FY-21AP. Set CH7 to VrC, to control the data overlay of the FYOSD.



12. Adjust the three dial knobs. Turn all in one direction. ON your transmitter and connect power to your plane. Switch the FY-21AP to **Flight Mode 2: Stabilized Mode**:

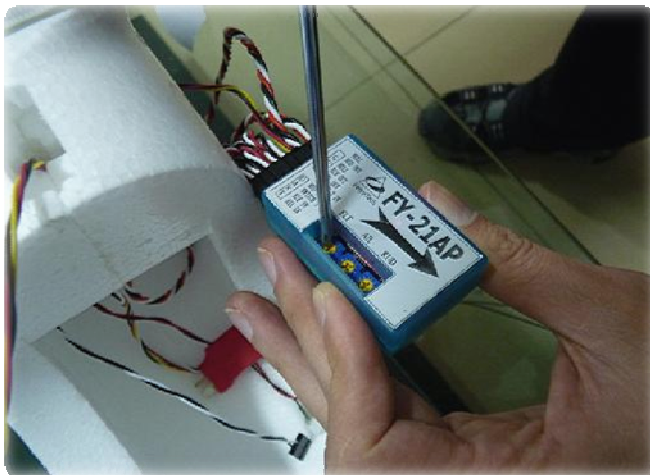

- i. Check the automatic movement direction of each servo.
- ii. Reverse dial knob rotation if servo movement is incorrect.



13. Connect the data wirings from GPS Module and FYOSD to the FY-21AP. Velcro tape the RC receiver to the FY-21AP. Velcro tape the FY-21AP to the vibration absorbing mount.

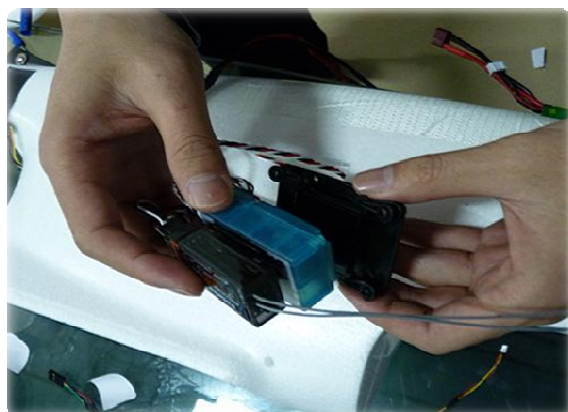

14. Use double sided tape to fix the vibration absorbing mount to the plane's center of gravity.

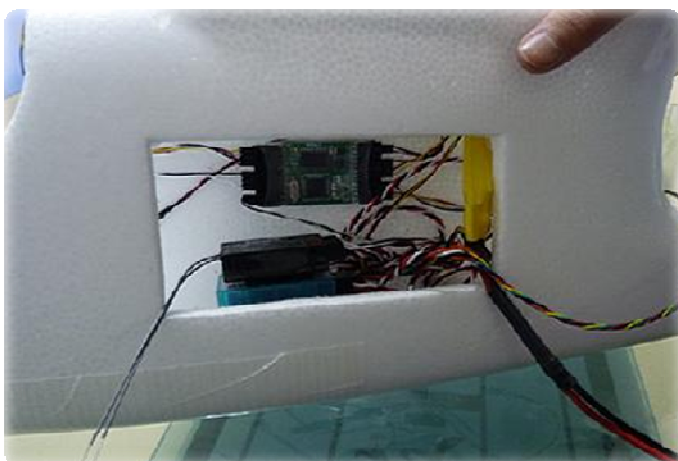
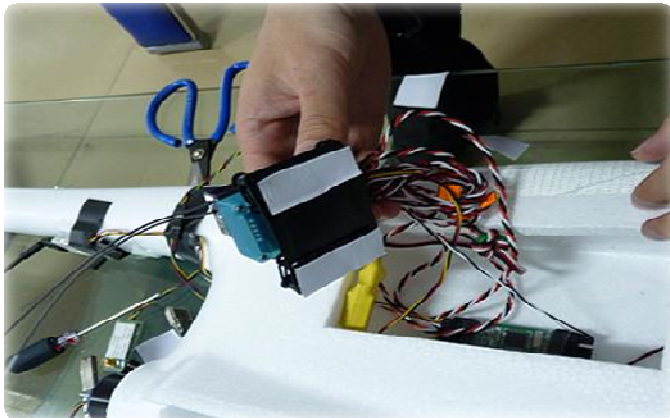

15. Install Current sensor between the ESC and battery:

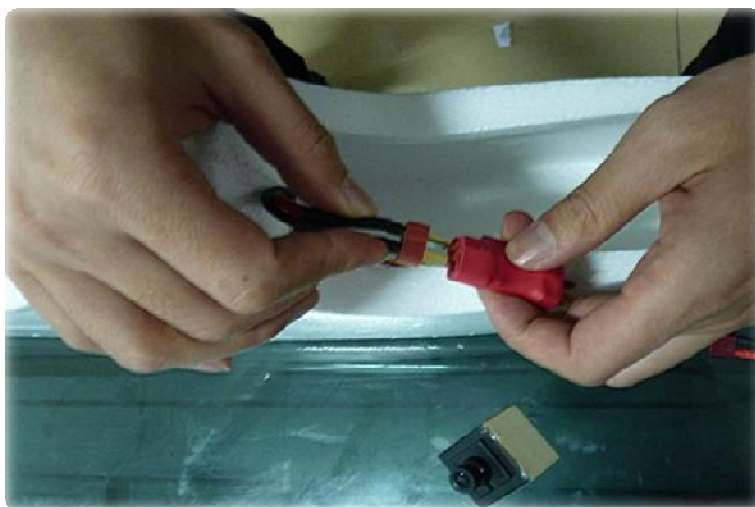

16. Fix the camera and GPS module:

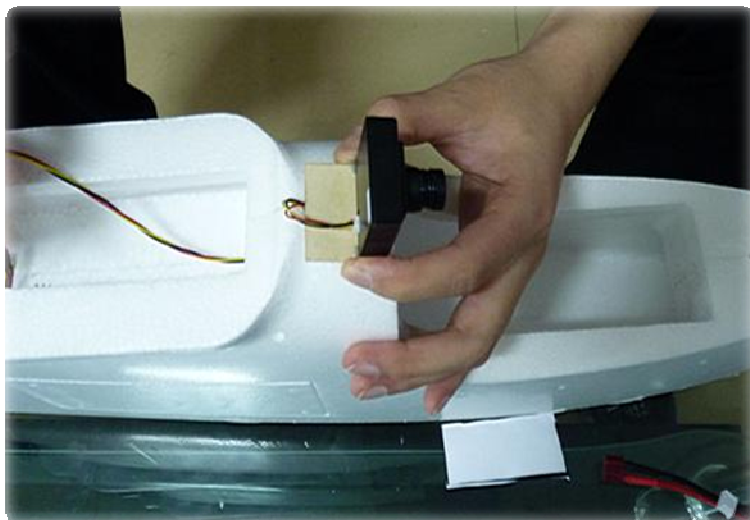

17. Arrange the wires neatly inside the aircraft cabin (avoid the GPS Module). Installation is complete. Go fly!



Note: *FeiYu Tech* reserves the right to change this manual at any time.