

RJX HOBBY

ASSEMBLY INSTRUCTIONS

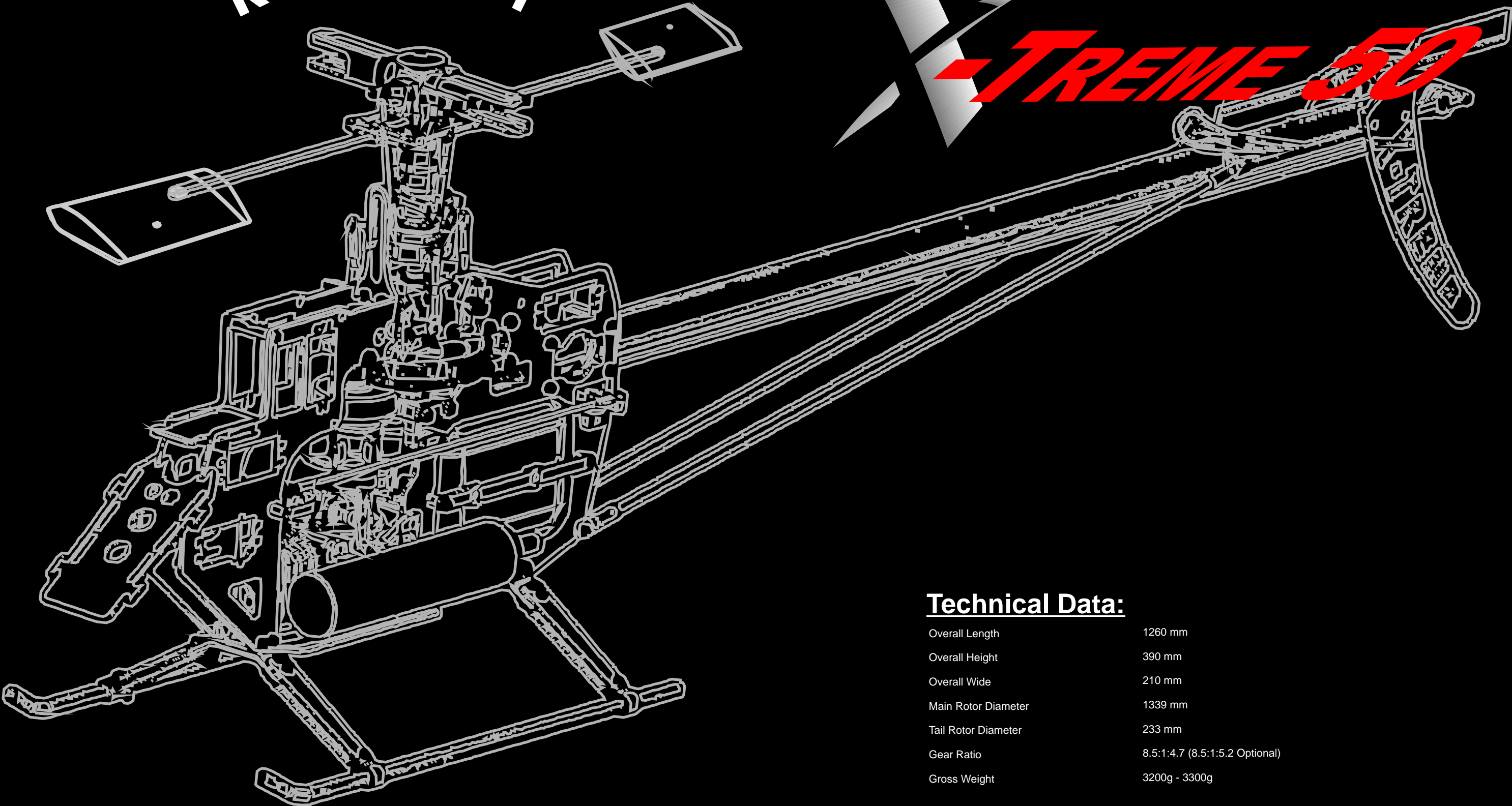

Technical Data:

Overall Length	1260 mm
Overall Height	390 mm
Overall Wide	210 mm
Main Rotor Diameter	1339 mm
Tail Rotor Diameter	233 mm
Gear Ratio	8.5:1:4.7 (8.5:1:5.2 Optional)
Gross Weight	3200g - 3300g

www.rjxhobby.com

PLEASE READ AND UNDERSTAND THE INSTRUCTIONS THOROUGHLY BEFORE ASSEMBLY

INTRODUCTION

Please read this manual carefully. It is essential for the correct assembly of the



For the correct assembly and safe flying, this manual uses this  symbol where special attention is required in the assembly of your model. It is very important that you follow the instructions at these points in the manual. Failure to do so can lead to the loss of control of the model without warning and the possibility of serious accidents or injury.



NOTE Failing to carry out the instructions at this point in the assembly manual will probably result in an electronic or mechanical failure occurring without warning..



IMPORTANT Means that special care is required at this point for correct assembly.

Disclaimer:

Whilst every effort has been made to supply the correct information in this manual, The Manufacturer and Distributor cannot guarantee that the purchaser will interpret or follow these instructions as intended and therefore the Manufacture and Distributor assumes no liability for damage or claims that may occur from the use/misuse of this product.

Do not be fooled it is NOT easy to fly R/C Helicopters

It may look easy when watching an experienced pilot flying his model, but perseverance and hours of practice will be needed before you will be able to fly and operate the model safely. R/JX HOBBY suggests you join a club or seek help from an experienced pilot to help you in your first hops off the ground and then as with all things the more you practice the better you will become. Who knows you could be the next world champion.

WARNING

The fuel used in model helicopter engines is highly inflammable and poisonous to human beings. For your own safety and that of others, you should exercise care when handling and storing it. Always read the label on the container and please note the cautions below.

1. Model helicopter fuel is highly inflammable. Do not smoke or light fires near your fuel.
2. We recommend that you keep your fuel in metal cans or plastic bottles and to store it where there is no risk of fire.
3. Please keep fuel away from the starter battery. It only needs one spark and.....!!!
4. Wipe up spilt fuel immediately. Do not take any chances.
5. Do not leave fuel in the sun or in your car on a hot day.
6. Before refuelling, shut off the engine and wait until it cools down.
7. Always drain the fuel tank of your helicopter at the end of a flying session. It is good practice.

TABLE OF CONTENTS

1. Introduction	I1
2. Table of contents	I2
3. Additional Items Required	I3
4. Tools Required	I4
5. Assembly	A1 - A28
6. Servo Installation	S1-S4
7. Servo Adjustment	S5-S6
8. Rotor Head Setup	Rh1-Rh3
9. Final Servo and Radio Setup	R1-R5
10. Please read before flight	Pf1
11. Spare Parts List	SP1 - SP6

HOW TO USE THIS INSTRUCTION MANUAL

This manual contains the detailed instructions to build and set up the *X-TREME 50*. Please follow it to ensure that you achieve the best performance and mechanical integrity from your finished kit. For those of you who already have experience of model helicopters, we still suggest that you assemble and adjust your model according to these instructions for the best results. Please keep your copy of this manual in a safe place and refer to it when replacing spare parts or upgrading.



Remove oil and grease then apply threadlock. (This applies throughout the manual)



Remove oil and grease then apply threadlock. (This applies throughout the manual)

Please refer to the list at the end of this instruction manual when you need spare parts.





TO PREVENT LOOSE SCREWS AND BOLTS

Regardless how tight the nuts, bolts and screws are tightened, they will still slowly come loose over a period of time due to vibration from the helicopter. Should this happen the helicopter will become out of control or severely damaged causing a very potential dangerous situation.



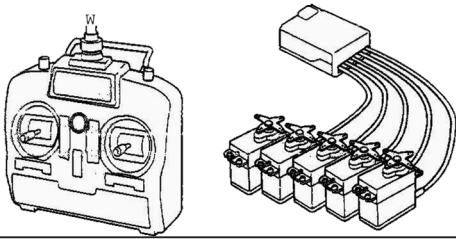

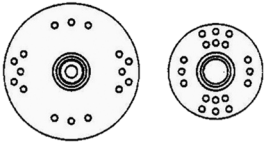
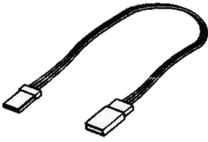
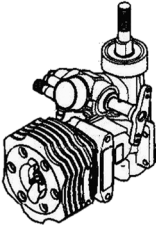
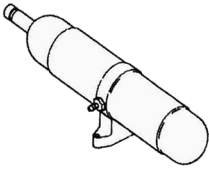
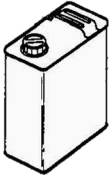
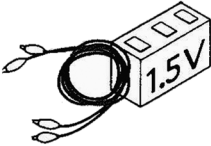
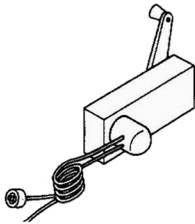
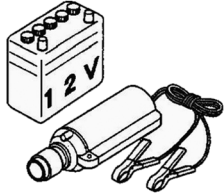

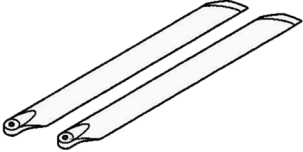









We strongly recommend that you apply threadlock to any nuts, bolts or screws that are indicated by these signs.

There are two types of threadlock, blue (soft) and red (hard). Use blue threadlock on screws that have to be removed regularly and red threadlock for screws that should be fixed permanently.

ADDITIONAL ITEMS REQUIRED TO COMPLETE THE *X-TREME 50*

				
<p>Choose a CCPM compatible PCM Radio System for Helicopters with a minimum of 6 channels.</p>		<p>Gyro system with Heading Hold</p>	<p>Three large and two small disks or arms are required</p>	
				
<p>1x Servo extension 100 mm</p>		<p>50 Size glow engine, Os 50 Hyper, Ys50</p>		<p>50 Size Muffler (for kits without Muffler)</p>
				
<p>Helicopter fuel: 15% - 30% Nitro, 18% - 23% Oil</p>	<p>1,5V Glow Plug Battery and glow plug connector</p>	<p>Fuel Pump</p>	<p>12V Electric Starter</p>	
				
<p>Starter Extension</p>	<p>Fuel Filter</p>	<p>600mm - 620mm Main Blades (for kits without Blades)</p>		

TOOLS REQUIRED (NOT INCLUDED)

			
Allen Drivers 1,5mm - 2mm - 3mm - 4mm	Phillips Drivers Large,Middle, Small	Nut Drivers 4,5mm - 5,5mm - 7mm	
			
Cutter	Universal Pliers	Scissors	
			
Sandpaper	Ball Link Plier	Metric Ruler	Pitch Gauge
			
Cyanoacrylate (CA/Superglue)	Epoxy 30 Minutes	Grease	
			
Ball Link Driver		Universal RC Cross Wrench	Ball Link Tool

STEP 1-1 Clutch Bell / Starter Shaft BB Block Assembly



IMPORTANT: Before assembling sand the inner side of the clutch bell and the side from the clutch liner you will glue in. Use 30 minutes EPOXY to glue the liner in the clutch bell and fix them with some clips to ensure a good and tight fit of the liner.

IMPORTANT:
 USE THREADLOCK
 REMOVE OIL
 CLEAN FROM OIL AND GREASE

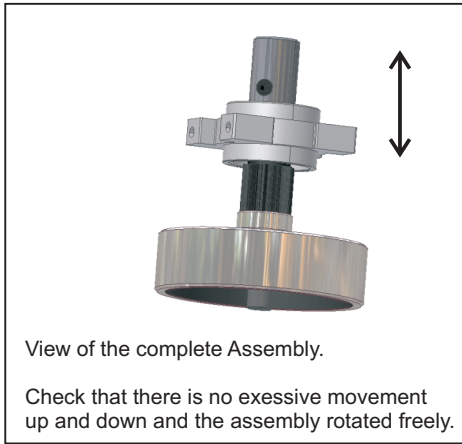
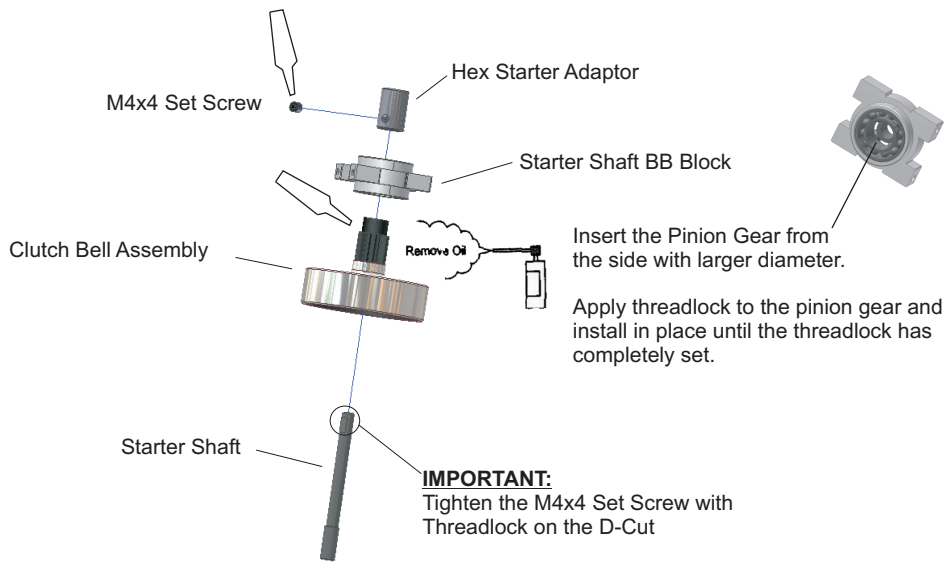

STEP 1-2 Tail Drive Pinion Gear Assembly



IMPORTANT:
 One end of the BB Block is machined with a flange to retain the Bearing. Assemble it as shown in the diagram below.

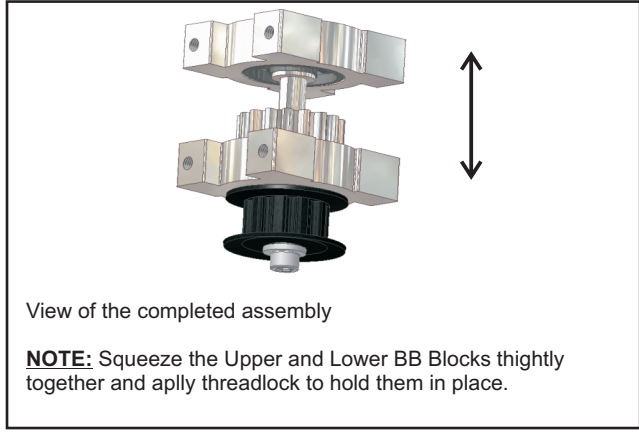
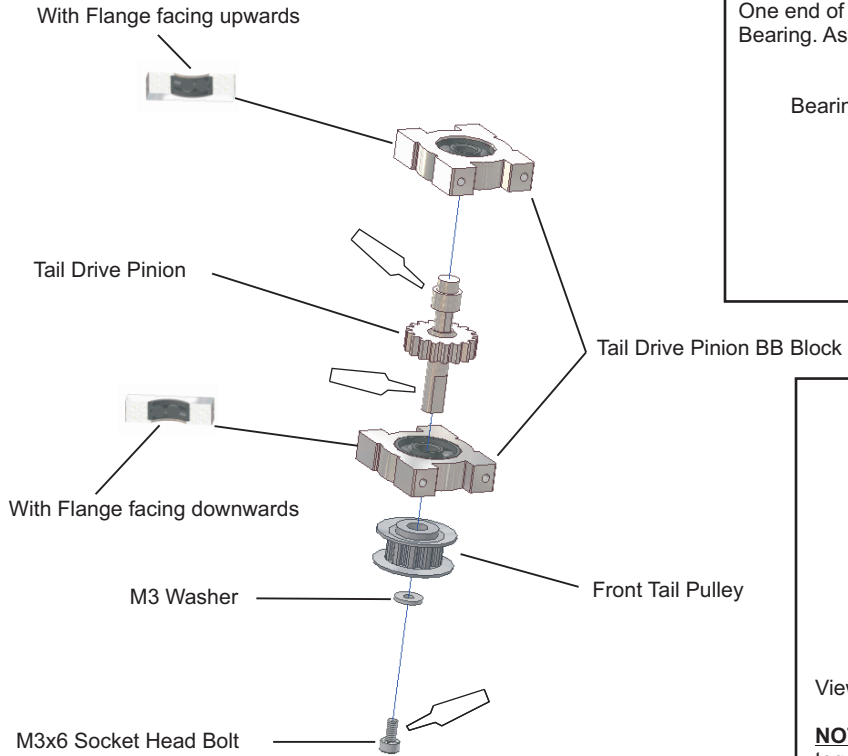

STEP 1-3 Drive Gear Assembly

USE THREADLOCK



CAUTION:

Clean off any dust on drive gears. Add grease to the one way bearing, to ensure smooth operation. Don't fix the four M3x6 bolts before having all four in place.

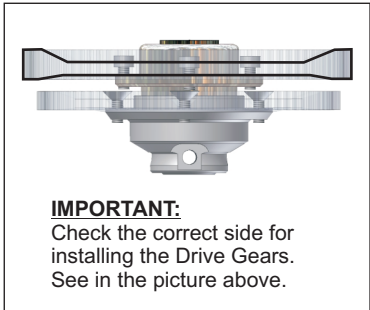
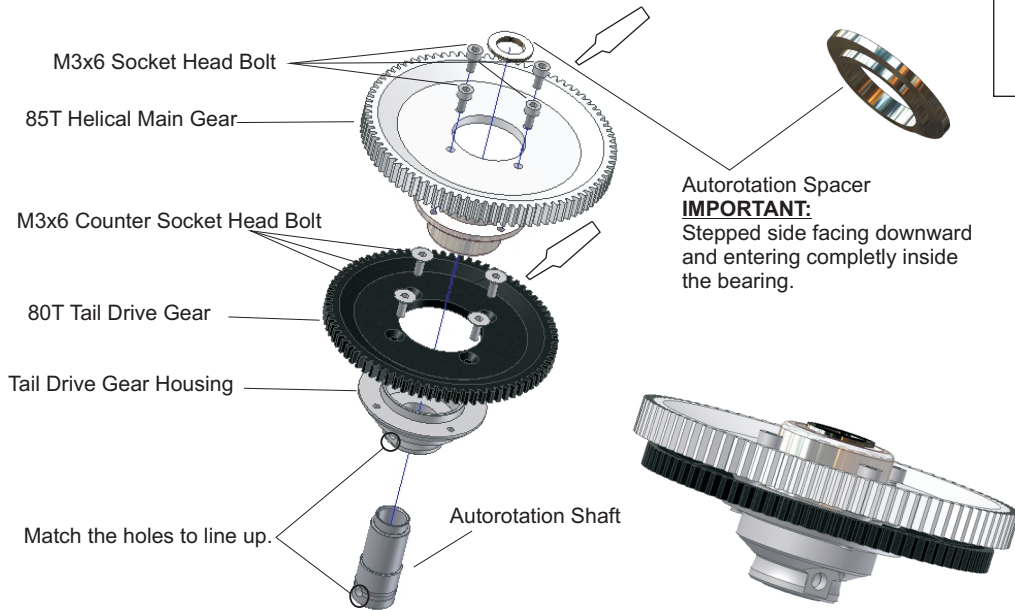

View of complete Assembly

STEP 1-4 Fuel Tank and AUX Tank Assembly

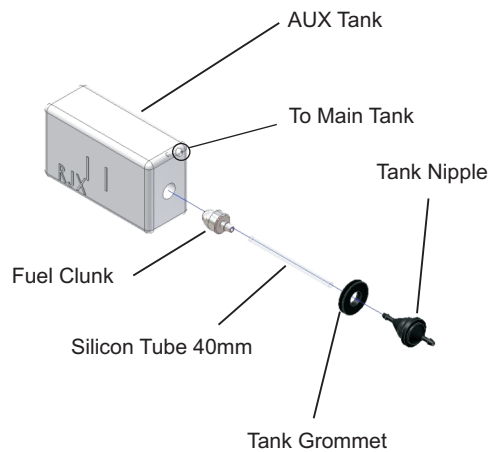
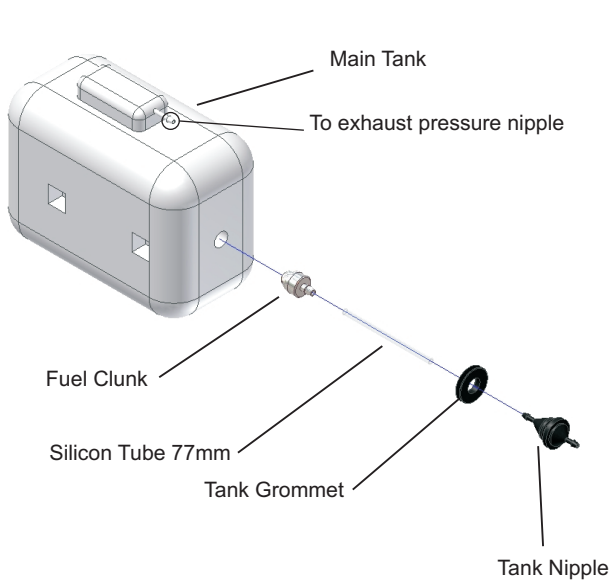

IMPORTANT:
Make sure that the Fuel Clunk can move freely inside the tank. **Be sure to replace the silicon fuel tubing inside the Main and AUX Tank regularly.**

NOTE:
Cut the fuel tubing to length using a hobby knife. So there is a clean cut.

STEP 1-5 Swash Control Lever Assembly

 **USE THREADLOCK**

CONTROL LEVER inside the bag of the MAIN FRAME

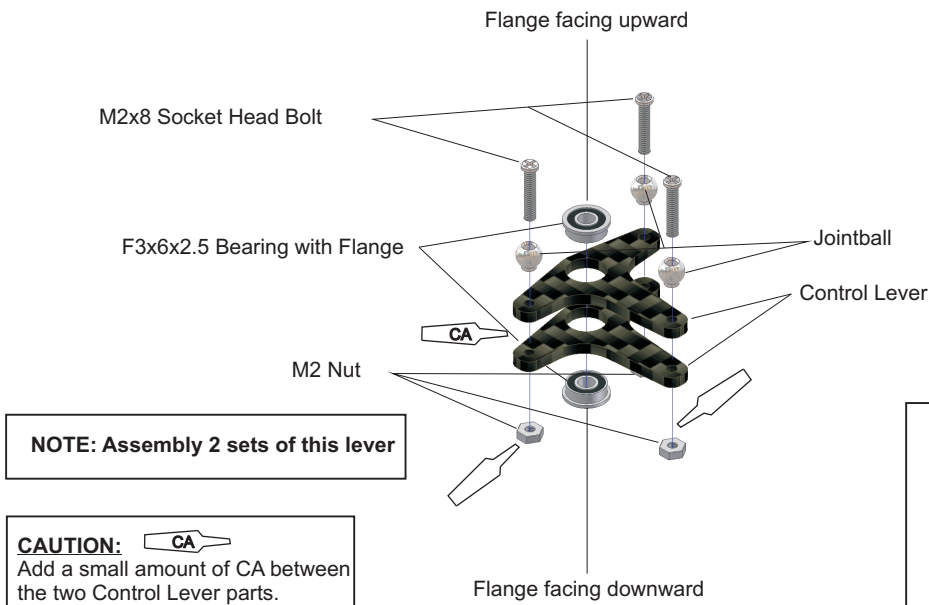

CAUTION: 
Control the correct fit of the Flanged Bearings.

NOTE: Assembly 2 sets of this lever

CAUTION:  Add a small amount of CA between the two Control Lever parts.

Add a 0.2mm Shim between the bearings if necessary

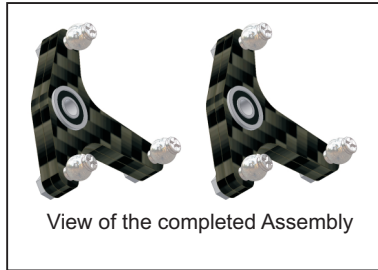

STEP 1-6 Rear Swash Control Assembly

 **USE THREADLOCK**

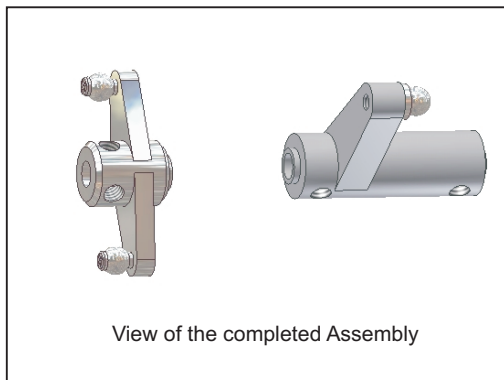
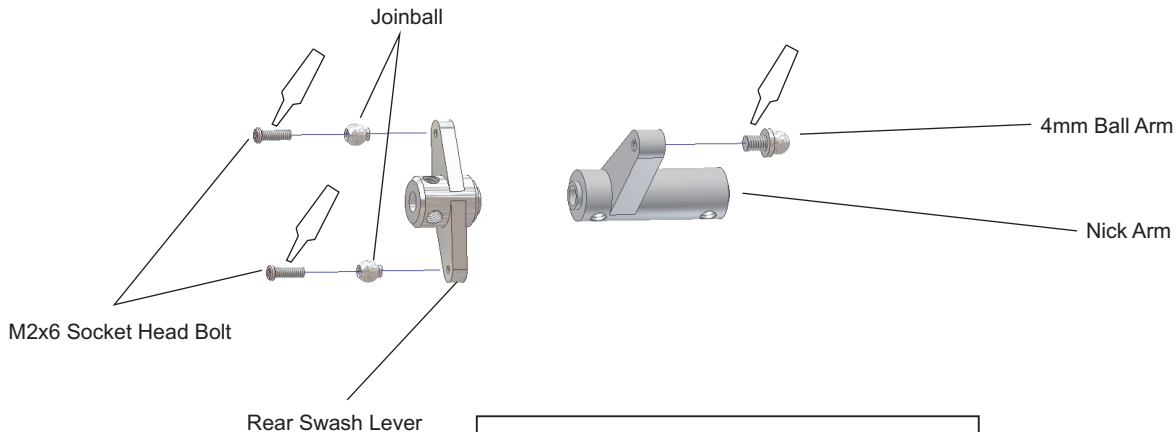

STEP 1-7 Front Tail Arm Assembly



M2x10 Socket Head Bolt

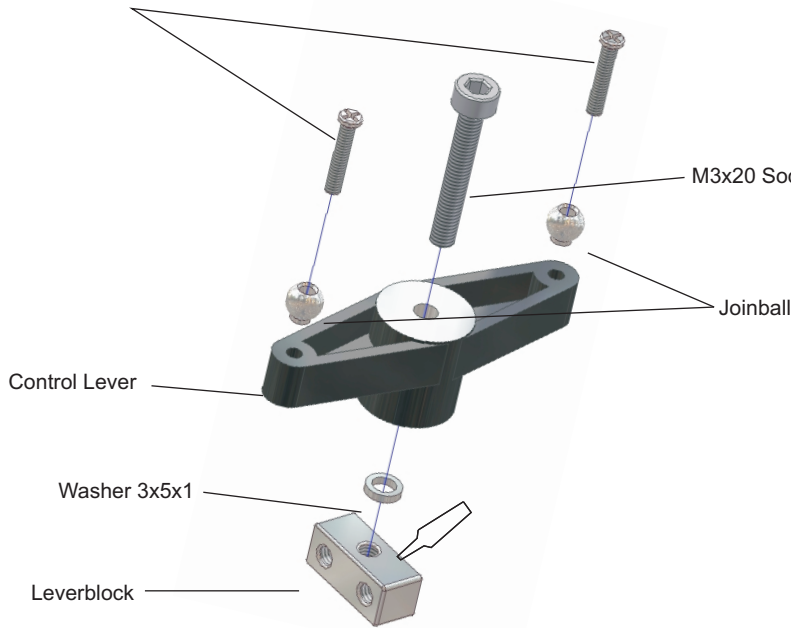

CAUTION:

Do NOT over tighten the M3x20 bolts to avoid breaking the bearings.

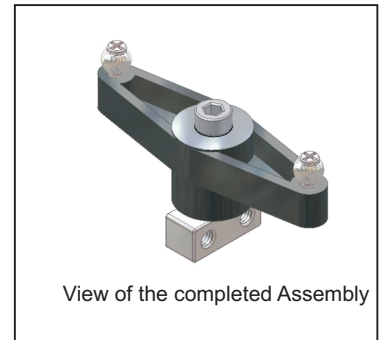

STEP 1-8 Battery Tray Assembly



BATTERY TRAY inside the bag of the MAIN FRAME

M3x6 Countersunk Head Bolt

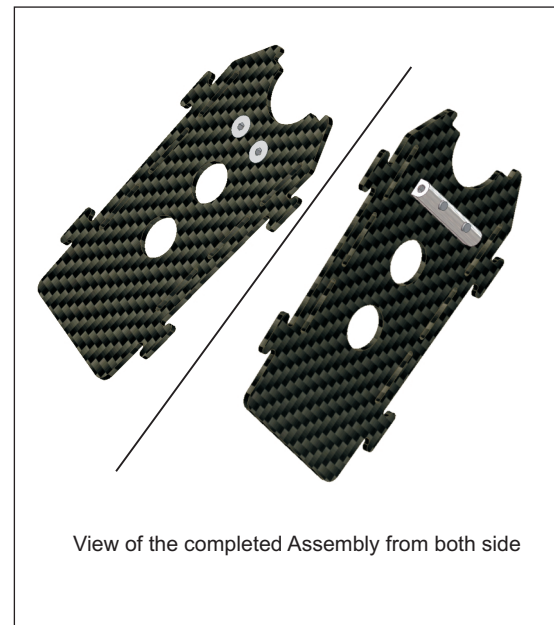
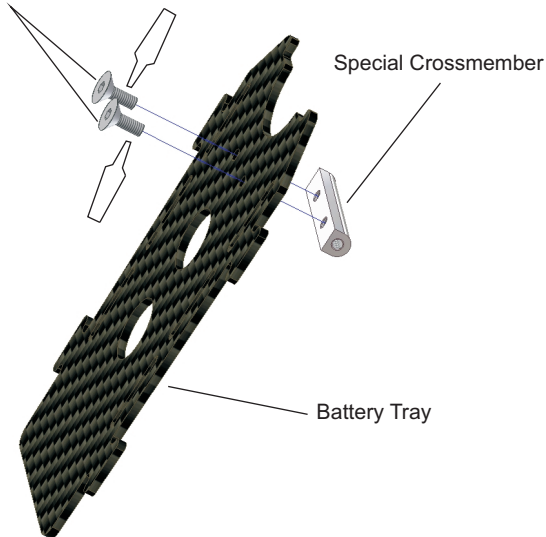

STEP 2-1 Main Frame Assembly

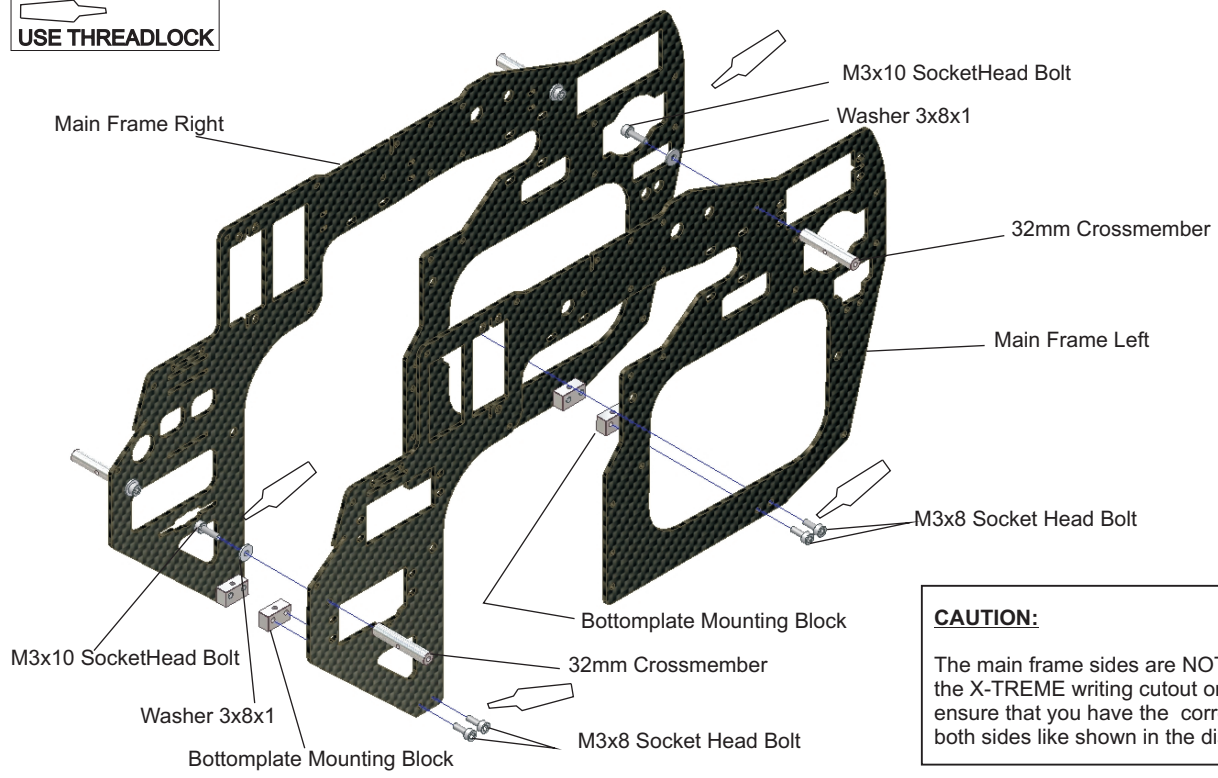

CAUTION:
The main frame sides are NOT the same. Look at the X-TREME writing cutout on the frame sides to ensure that you have the correct sides. Assemble both sides like shown in the diagram.

STEP 2-2 Main Frame Assembly



NOTE:
Place the Frame on a flat surface to mount the Bearing Blocks and the Crossmember.

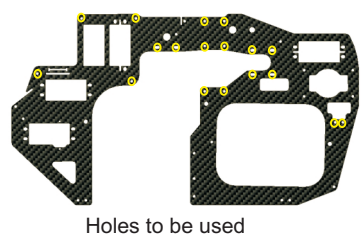
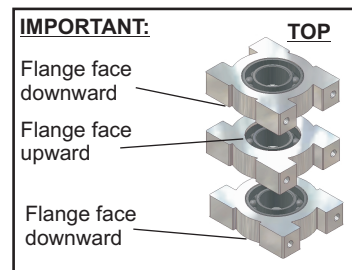
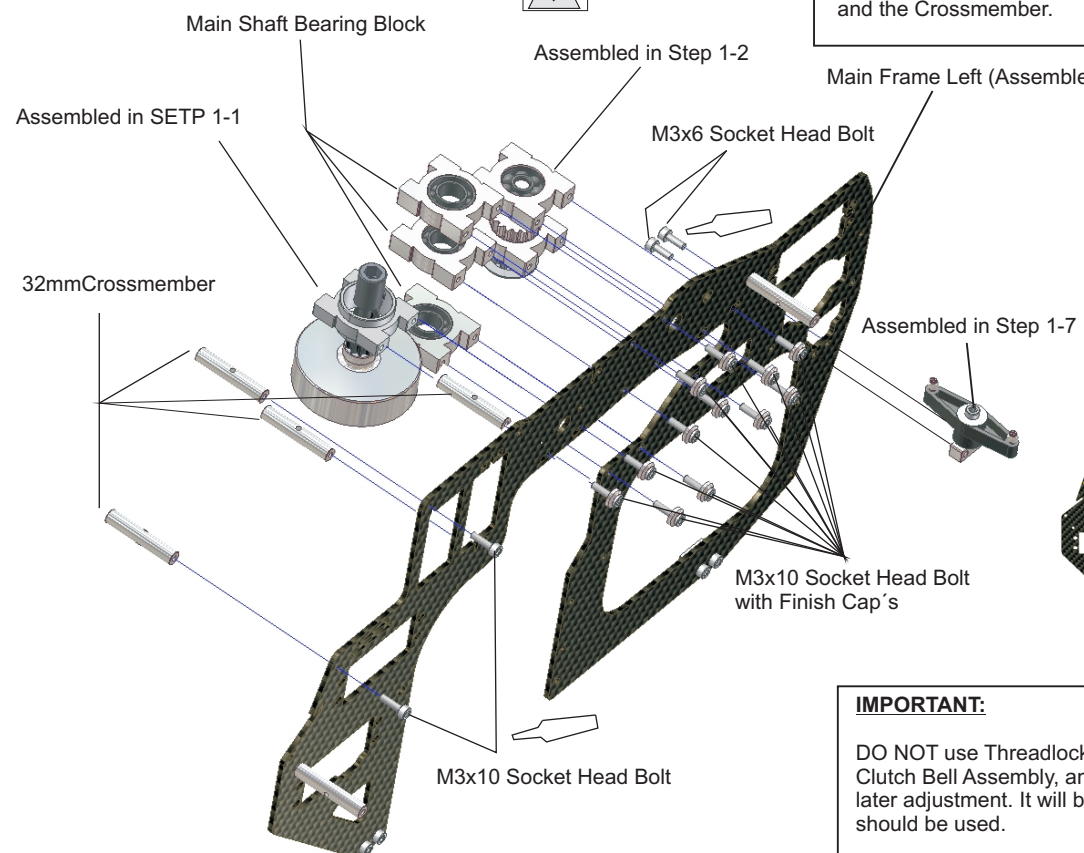

IMPORTANT:
DO NOT use Threadlock in this stage for the Bearing Blocks, Clutch Bell Assembly, and Tail Pinion Drive Assembly, for later adjustment. It will be indicated when Threadlock should be used.

STEP 2-3 Main Frame Assembly

Main Frame Left (Assembled in Step 2-2)

USE THREADLOCK

Gyro Tray (To fit into the upper cutout)

Main Frame Right (Assembled in Step 2-1)

M3 Lock Nut

Tailboom Holder

32mm Stepped Crossmember

M3x40 Socket Head Bolt

M3x10 Socket Head Bolt

Holes to be used

M3x10 Socket Head Bolt with Finish Cap's

View of the completed Assembly

IMPORTANT:
DO NOT use Threadlock in this stage for the Bearing Blocks, Clutch Bell Assembly, and Tail Pinion Drive Assembly, for later adjustment. It will be indicated when Threadlock should be used.

STEP 2-4 Main Frame Assembly

USE THREADLOCK

M3x8 Socket head Bolt

Assembled in Step 1-8

Main Frame Assembly in STEP 2-3

View of the completed Assembly

STEP 2-5 Main Frame Assembly

 USE THREADLOCK

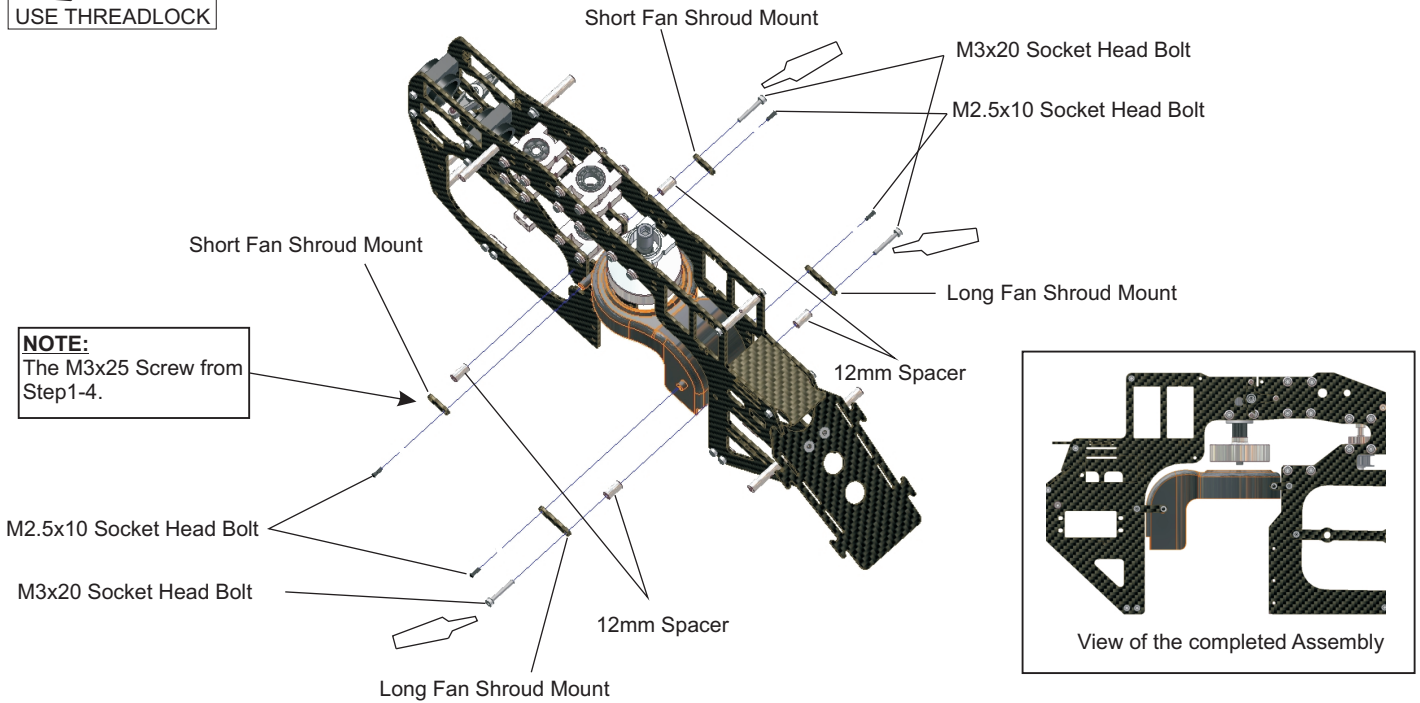

STEP 2-6 Main Frame Assembly

 USE THREADLOCK

TANK HOLDER inside the bag of the MAIN FRAME

NOTE:
This Screw is fixed on back of the frame with a M3 Lock Nut

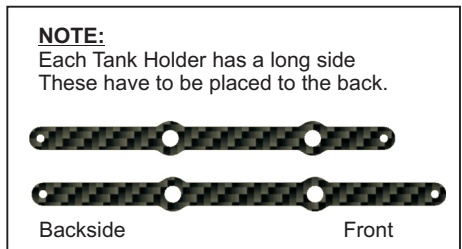
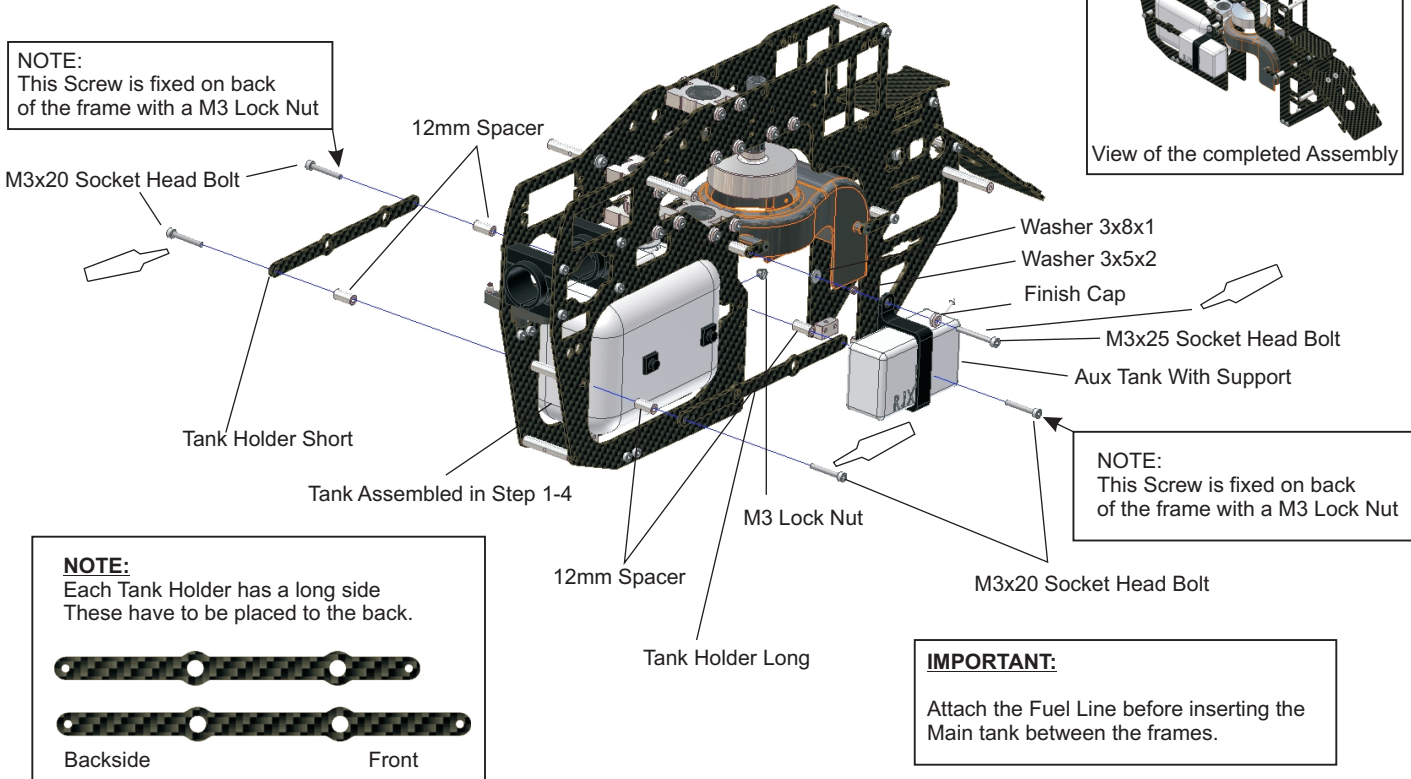

IMPORTANT:
Attach the Fuel Line before inserting the Main tank between the frames.

STEP 2-7 FRONT CCPM LEVER ATTACHMENT

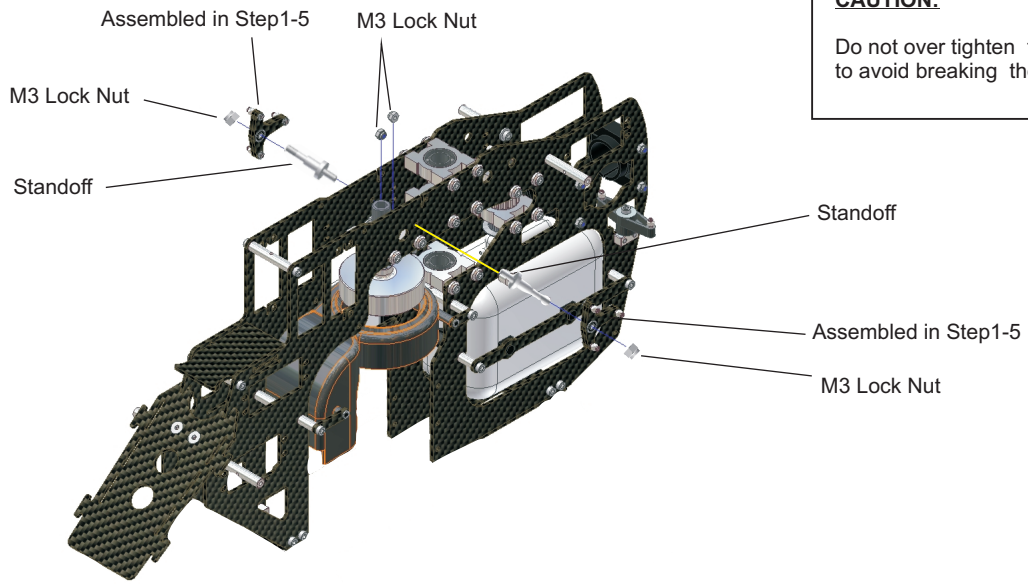

CAUTION:
Do not over tighten the M3 Lock Nut to avoid breaking the bearings.

STEP 2-8 REAR CCPM LEVER ATTACHMENT

 **USE THREADLOCK**

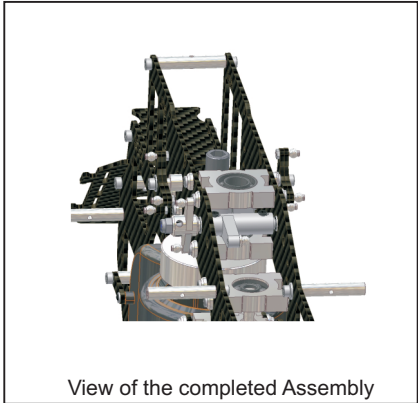
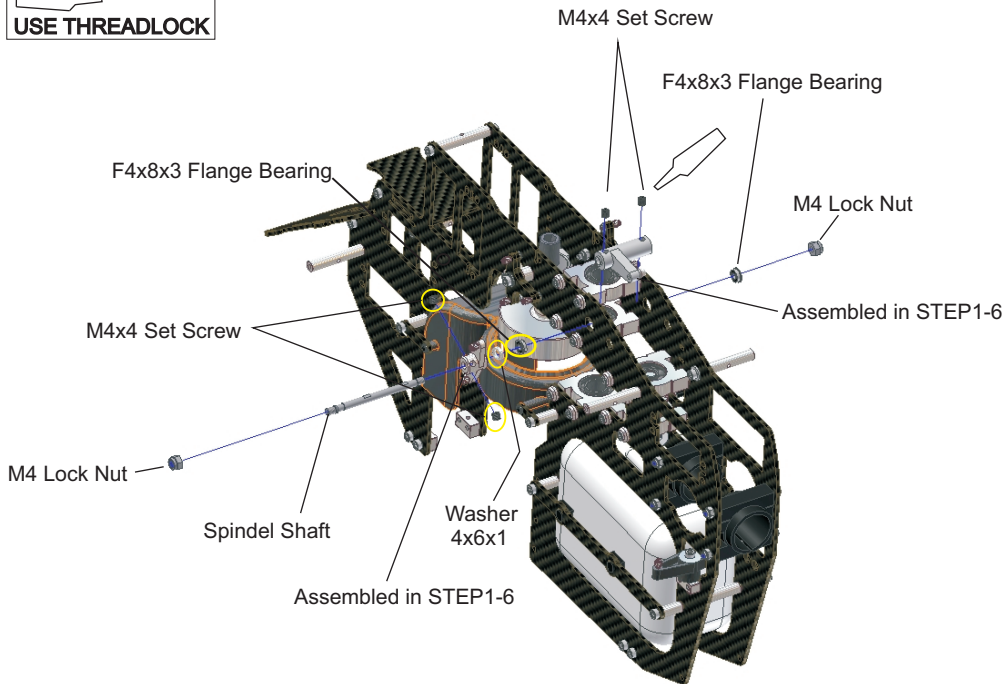

IMPORTANT:
Do NOT over thighten the M4 Lock Nut to ensure the smooth operation of the assembly.

STEP 2-9 Landing Skid Assembly

NOTE:
Assemble two sets. Do NOT tighten the screws for later adjustment.

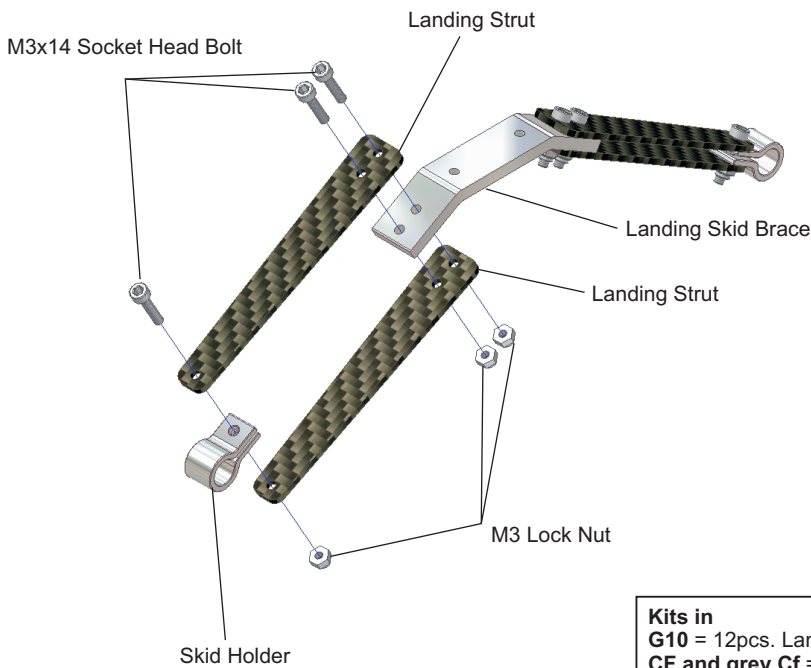

Kits in
G10 = 12pcs. Landing Struts
CF and grey Cf = 8 pcs.

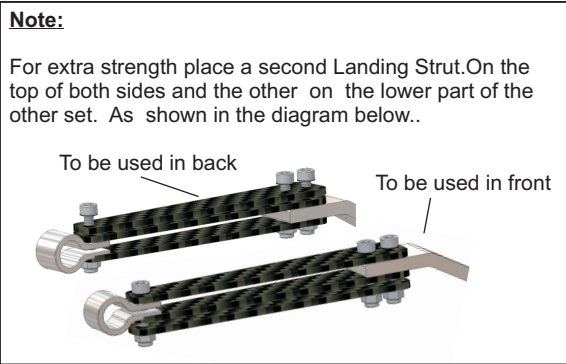

STEP 2-10 Landing Gear Assembly

NOTE:
Place the complete assembly on a flat surface. Do NOT tighten the screws yet

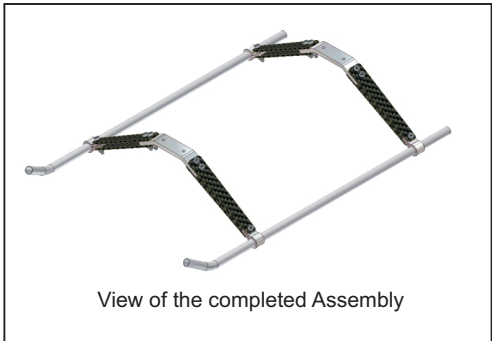
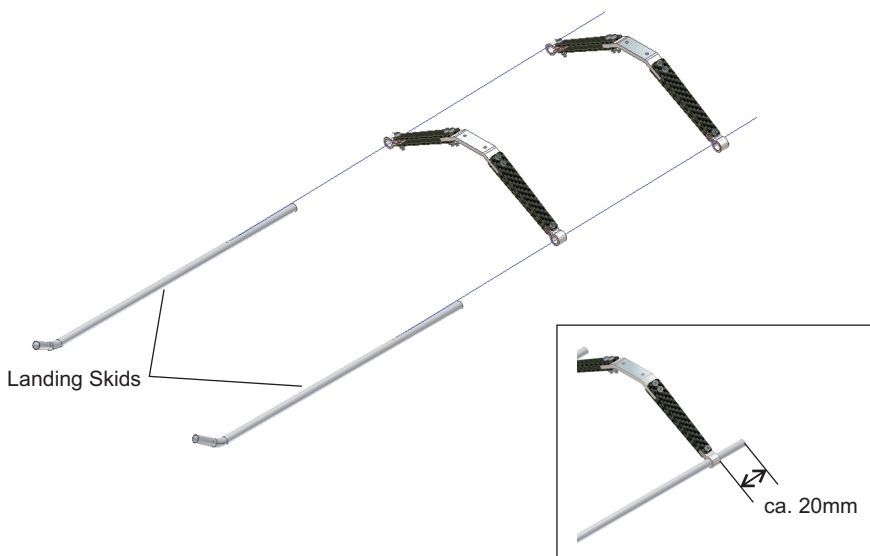

STEP 2-11 Landing Skid Assembly

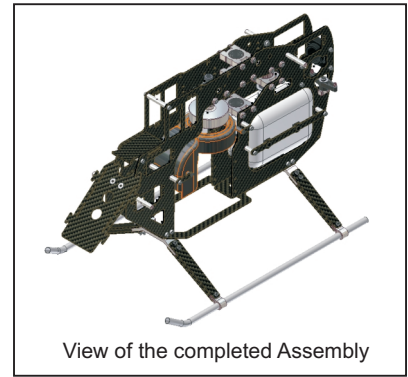

NOTE:
Place the complete frame after assembling on a flat surface and tighten the screws from the Landingskid assembly. Insure that the the skids are flat on the surface.

STEP 2-12 Main Shaft / Drive Gear Assembly

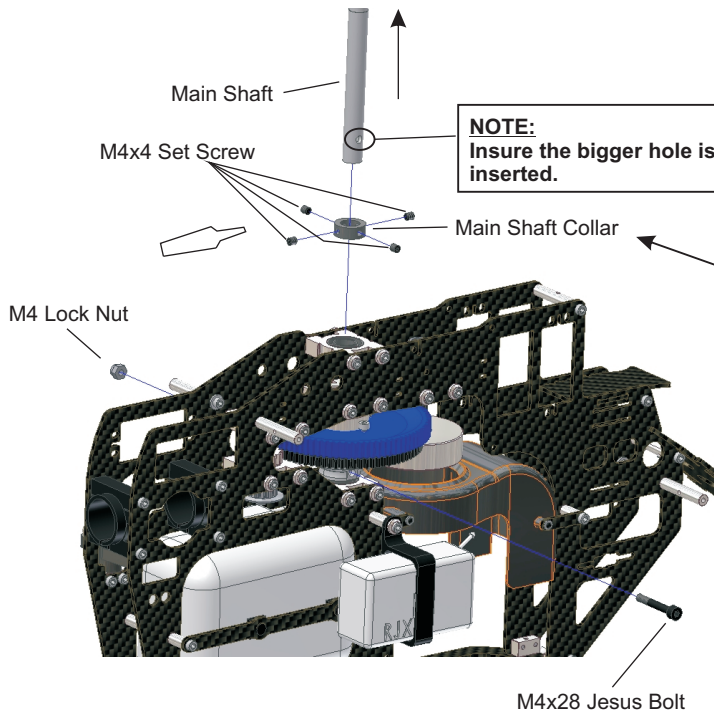

NOTE:
Insure the bigger hole is inserted.

IMPORTANT:
When securing the main shaft, pull it upwards through the main bearings to eliminate any freeplay. Next press the main shaft collar firmly onto the upper bearing block and fix with threadlock the four M4x4 set screws.

NOTE:
DO NOT tighten the Jesus Bolt too much. If tighen to much the Tail Gear Housing could deform.

STEP 2-13 TAIL PINION GEAR MESH



IMPORTANT about GEAR MESH:

In order to archive smooth operation of the main drive train, it is important that the correct gearmesh is obtained after assembly. Try to mesh the gears to get the minimum amount of backlash and the smoothest rotation. Remember that too little clearance and the train will be too stiff to work properly and too much clearance may result the teeth stripping off when under load.

1.

First tighten all twelve M3x10 Socket Head Bolts from the bearing blocks with threadlock. This way a correct Gear mesh can be archived..Insure that there is no up and down play in the mainshaft. If there is any freeplay then readjust the mainshaft collar and tighten the set screw.

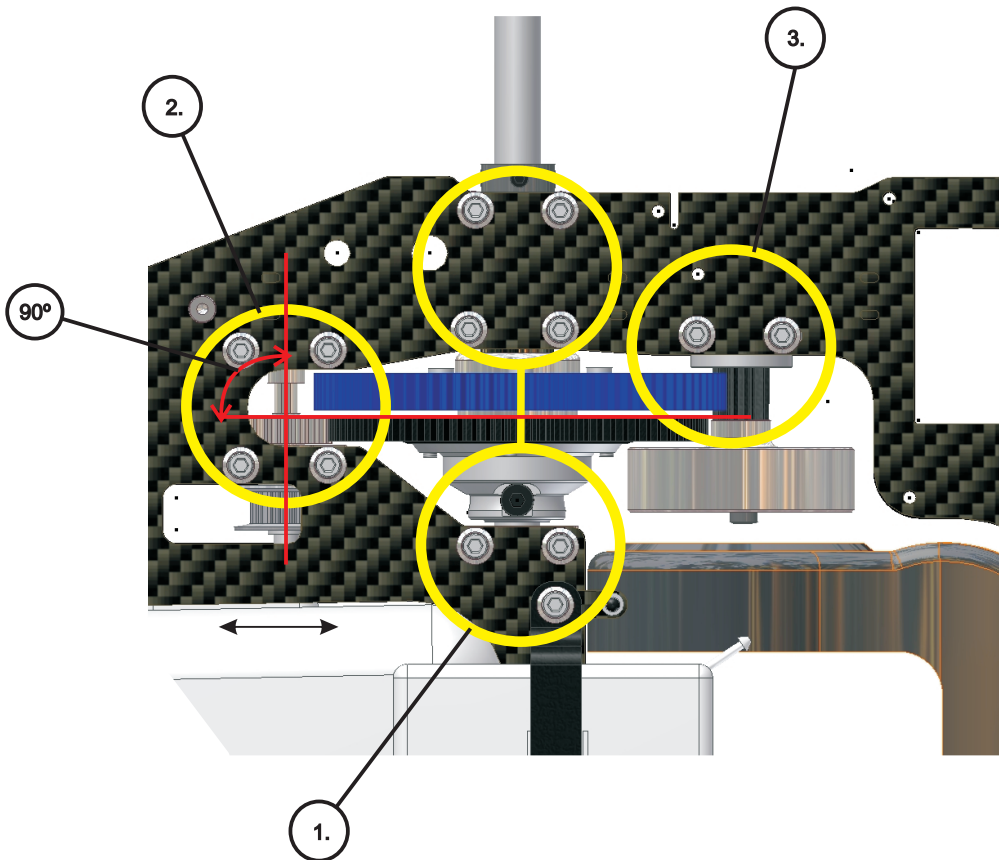

Step by Step to get a correct Gear Mesh:

2.

Starting with the tail gear and tail pinion gear.

Cut from a normal piece of printing paper a slice aprox. 15cm long and 5mm high and pass it between both gears.

Turn the main train to ensure that the paper runs through the gears and obtain a correct mesh.

Now press the Tail Drive Pinion Gear Assembly (STEP 1-2) firmly against the main train and secure the eight M3x10 Socket Head Bolts with threadlock.After finishing the gear mesh don't forget to take out the paper between the gears.

3.

The Gear mesh between clutch pinion and main gear will be done after installing the engine in STEP 4-8.

STEP 3-1 COOLING FAN ASSEMBLY



NOTE:

If a drive washer is included with the engine you will need to remove this. (Contact your dealer for information). For OS Engines, the thin black washer supplied will be used under the bottom collet.

Clean the top and the bottom taper collets and clean the taper inside the cooling fan hub before assembly. Any small particles of grit may cause the final assembly Not to run true

Identify the correct taper collet from the kit and push it right into the engine shaft so that it goes up against the front engine bearing. The collets may be a little tight on the crankshaft so a good push may be needed. Note that the black washer goes on first if you are using a OS Engine.

Assemble as shown in the diagram and secure the engine nut tightly. It is suggested that you use a piece of towel or cloth wrapped around the engine and the fan hub so that you can hold them tightly when doing this operation.

NOTE: TO BE DONE BEFOR ASSEMBLY

Governor / RPM Limiter-Magnet Installation

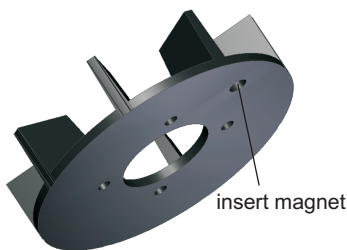

In the lower part of the fan blades you can install the magnet. clean the hole and the magnet carefully and apply EPOXY 30 MINUTE type. Insure the magnet is flat inside the small recess

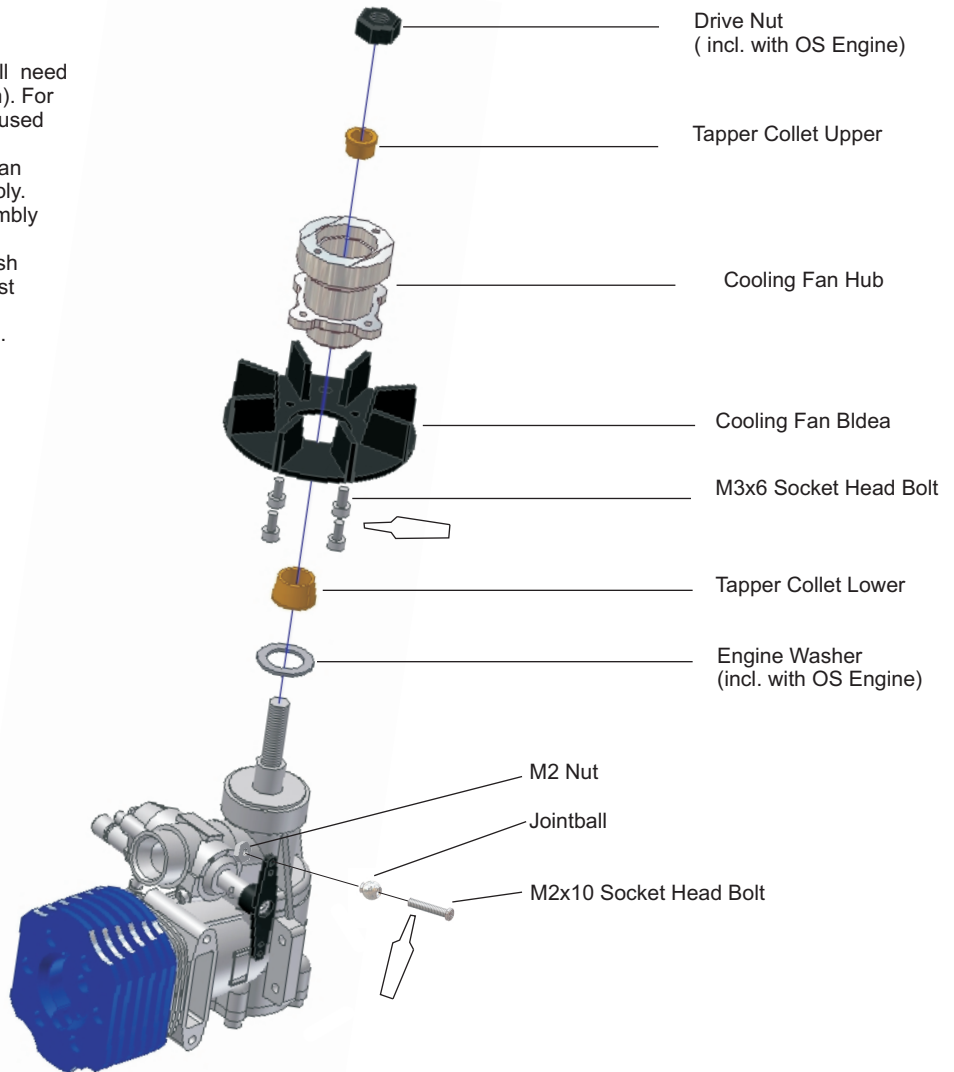

STEP 3-2 CLUTCH INSTALLATION



IMPORTANT:

Be sure to keep the clutch shoe square to the fan hub when tightening the securing bolts. Tighten each bolt a little at time and keep checking as you proceed.

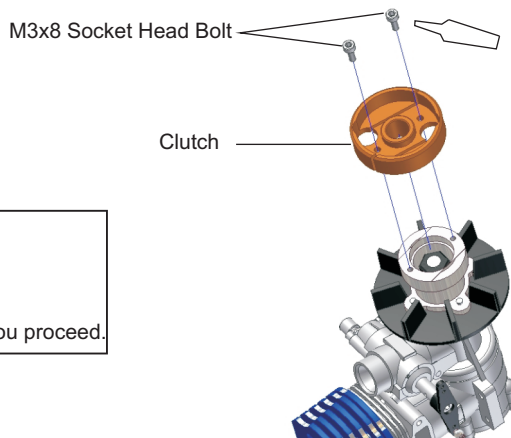

STEP 3-3 ENGINE INSTALATION

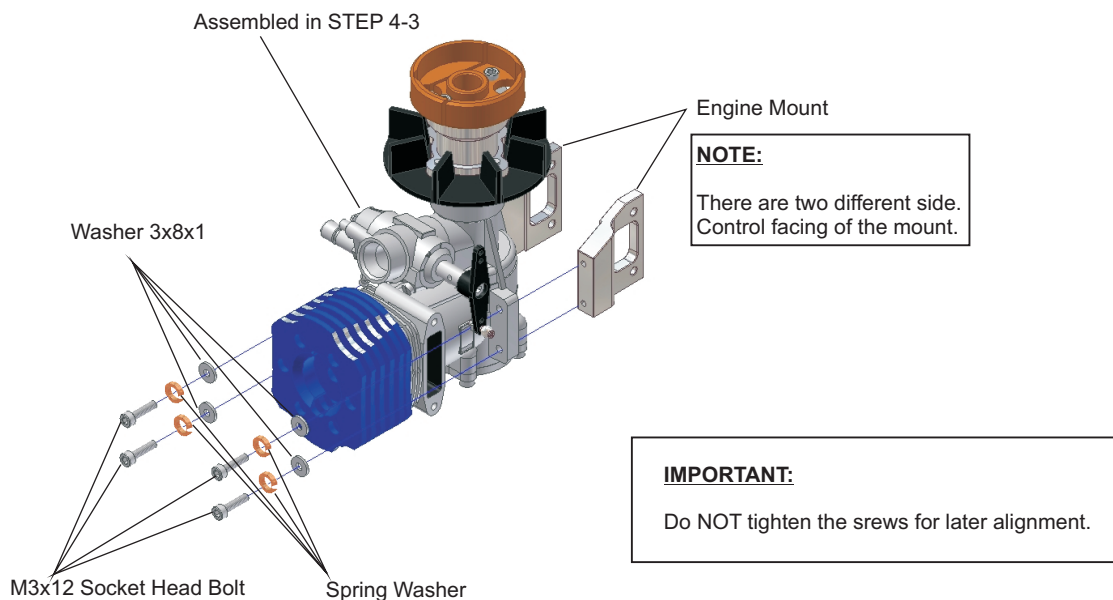

STEP 3-4 ENGINE INSTALATION

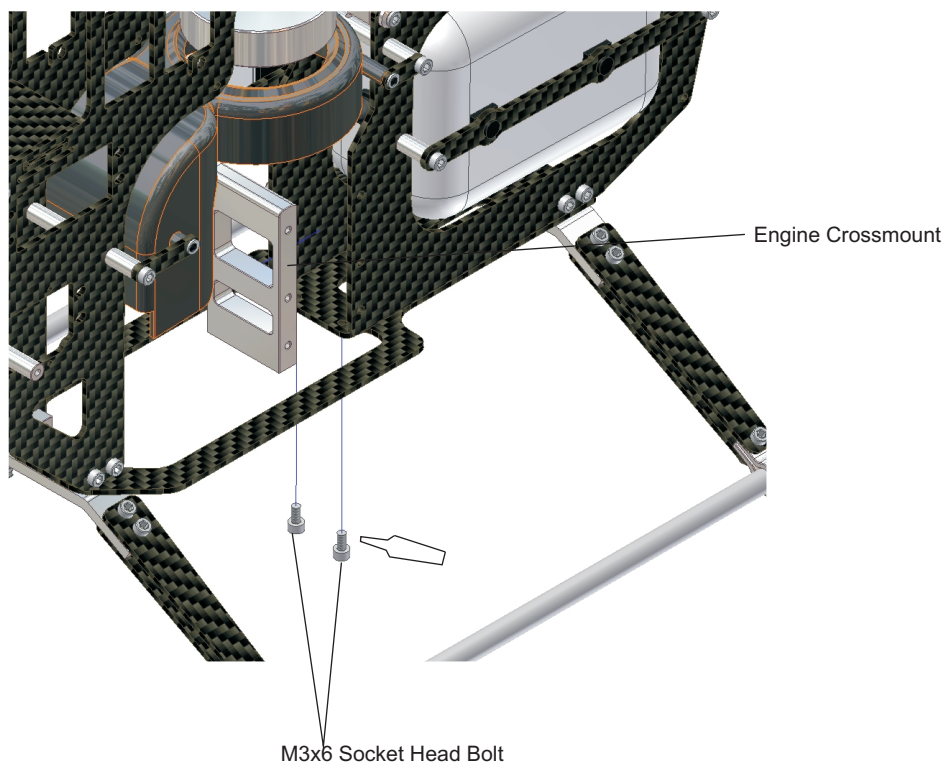

STEP 3-5 ENGINE INSTALATION

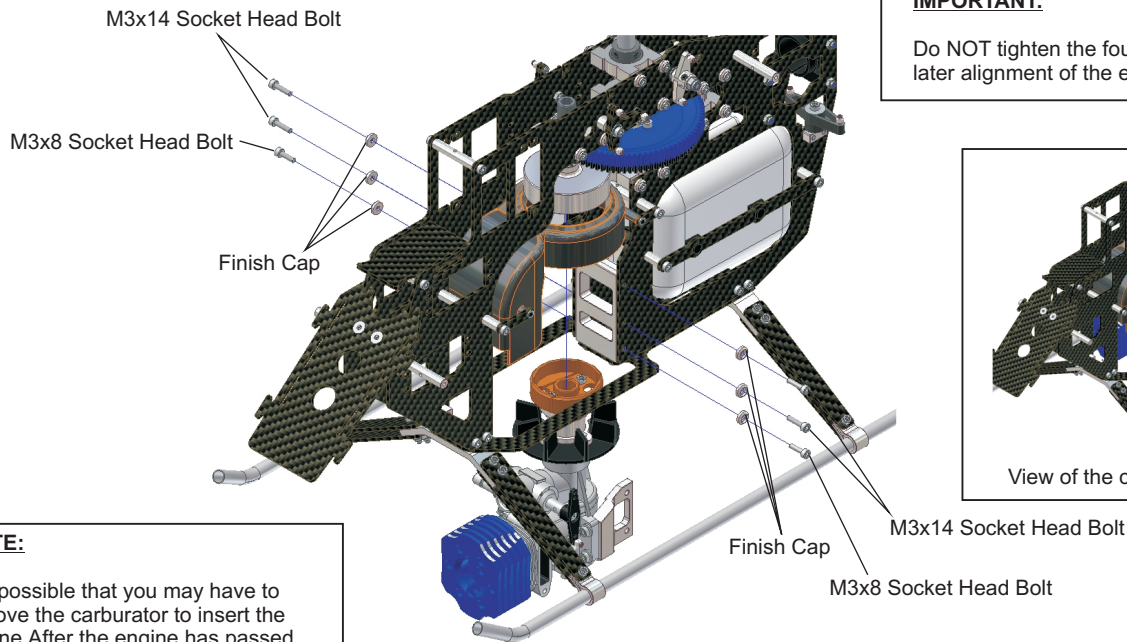

IMPORTANT:
Do NOT tighten the four M3x14 screws for later alignment of the engine.

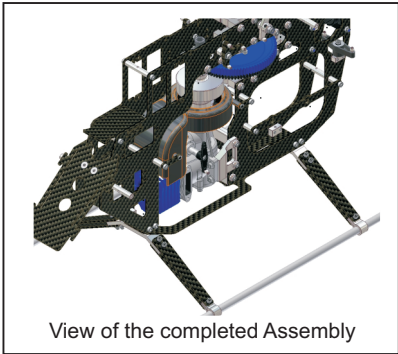

View of the completed Assembly

NOTE:
It is possible that you may have to remove the carburetor to insert the engine. After the engine has passed through the bottom plate reinstall the carburetor before inserting the engine completely.

STEP 3-6 ENGINE-PINION GEAR LINEOUT



IMPORTANT about GEAR MESH:

In order to archive smooth operation of the main drive train, it is important that the correct gearmesh is obtained after assembly. Try to mesh the gears to get the minimum amount of backlash and the smoothest rotation. Remember that too little clearance and the train will be too stiff to work properly and too much clearance may result the teeth stripping off when under load.

1.

Cut a aprox. 15cm long and 10mm high slice of normal printing paper and pass it between the main gear and the pinion gear. Rotated the main gear to introduce the paper and reach a good mesh. Press firmly the Clutch Bell Assembly against the main gear and tighten the four M3x10 Bolts. Insure that clutch bell is leveled and straight. Remove the paper and check that the main gear is running smoothly. Unscrew the M3x10 bolts one by one and apply threadlock and retighten them again. On this way you ensure the clutch system not move.

2.

Tighten and threadlock the four M3x12 Socket Head Bolts and ensure the engine is in line.

3.

Push the engine up, so that the clutch is standing approx. 1mm out of the clutch bell. Look from the side and ensure that the clutch is level with the clutch bell. Check that the starter shaft rotate freely and smooth. Carefully tighten the four M3x14 Bolts so you do not disalign the engine. Check the correct alignment the clutch is not touching the clutch bell and it runs smoothly. Now tighten the screws and double check that the engine is still in correct alignment. Unscrew one at a time the M3x14 bolts, apply threadlock then tighten. This stop the engine moving position

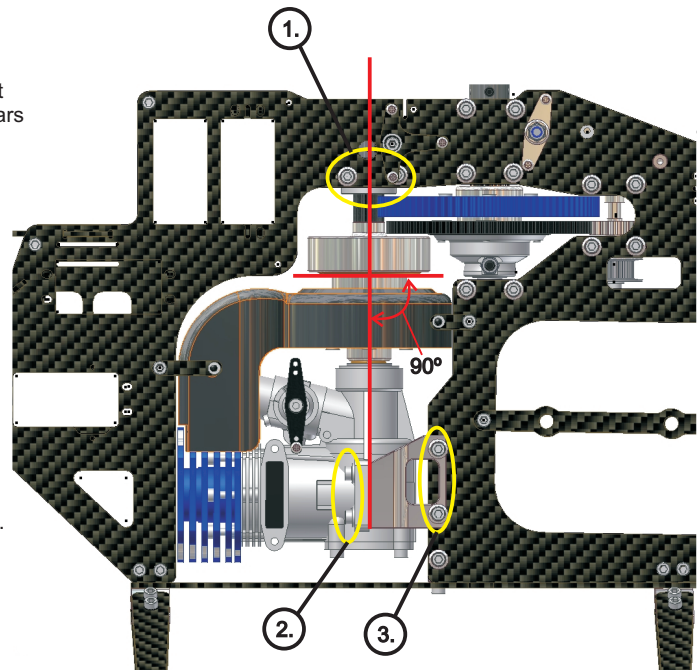

STEP 4-1 SWASHPLATE ASSEMBLY

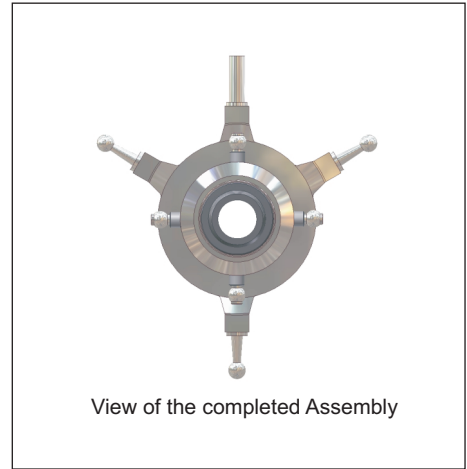
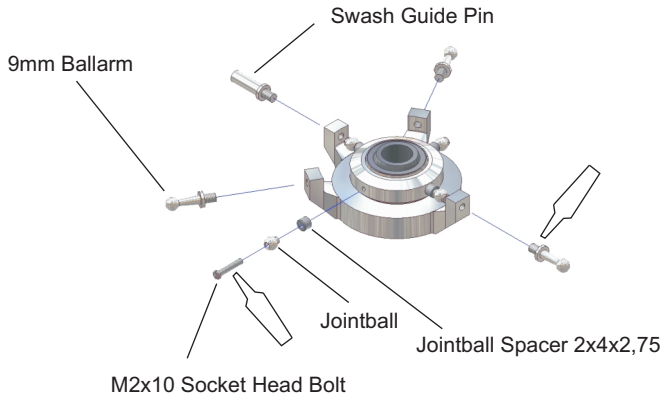

STEP 4-2 WASHOUT ASSEMBLY

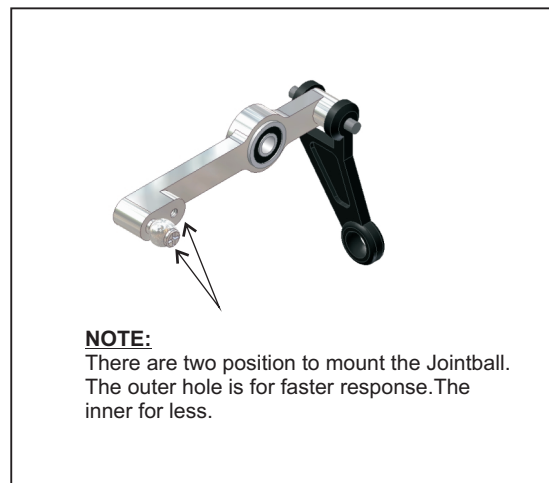
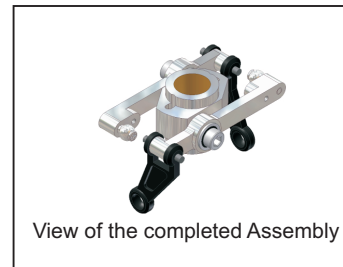
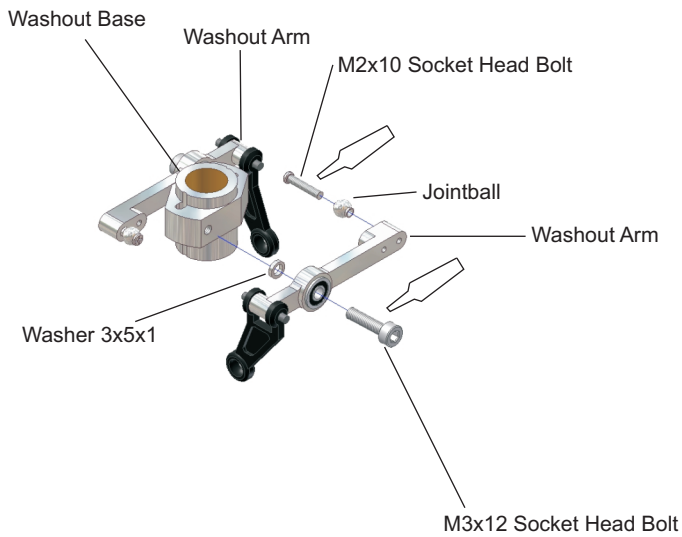

NOTE:
Do NOT over tighten the M3x12 Bolts to avoid damage to the bearings.

STEP 4-3 SWASHPLATE / WASHOUT INSTALLATION

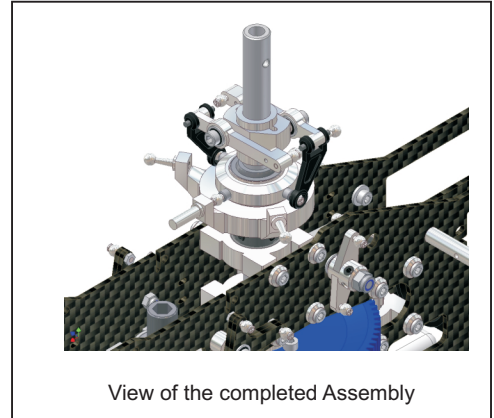
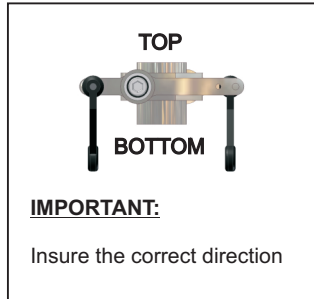

NOTE:
Attach the two Washoutlinks to the swash plate.

STEP 4-4 SEESAW INSTALLATION

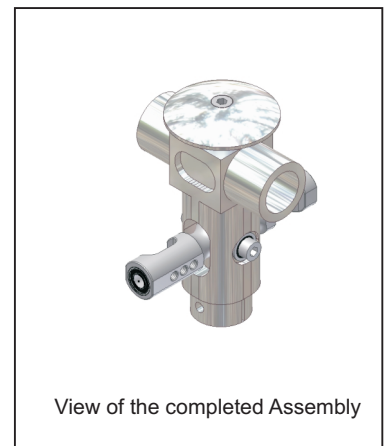
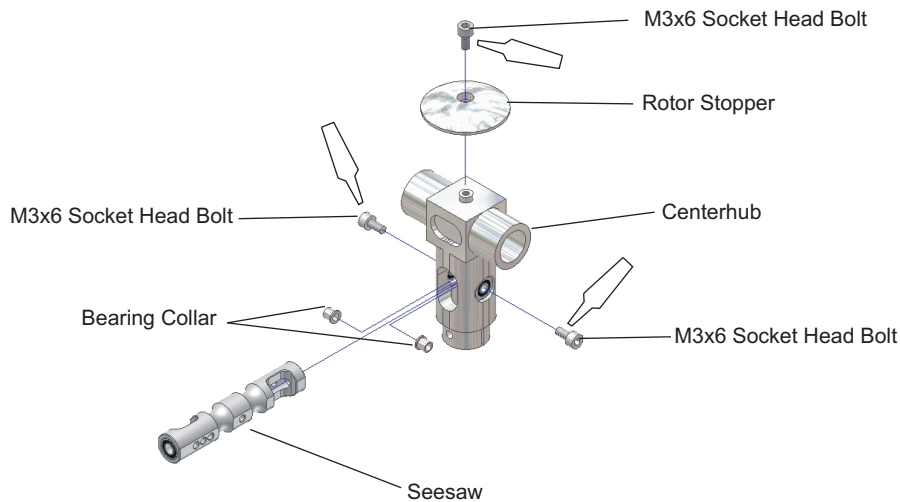

IMPORTANT:
Do NOT over tighten the M3x6 Socket Head Bolt to fix the Seesaw. Hard type of thread lock is necessary.

STEP 4-5 MAIN BLADE HOLDER ASSEMBLY

 **USE THREADLOCK**

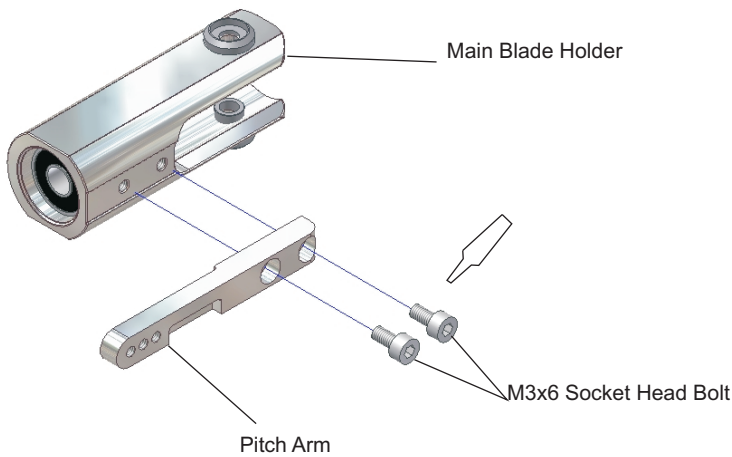

NOTE: Assemble 2 sets of the Main Blade Holder

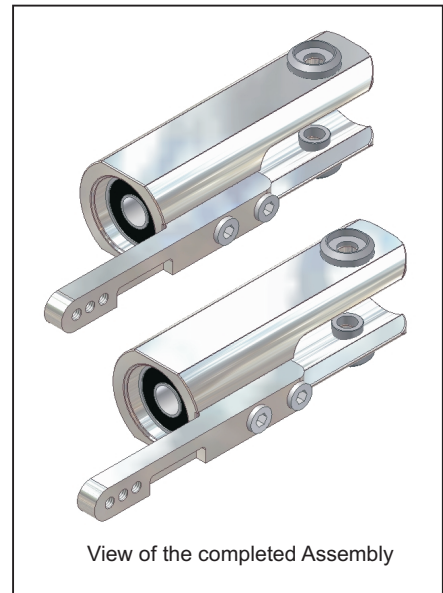

STEP 4-6 MIXER ARM ASSEMBLY

IMPORTANT:
Mixer settings are explained on Page Rh1 more detailed.

NOTE:
Don't use in this step threadlock to fix the Ball arm. It will be need to make adjustments in a later step.

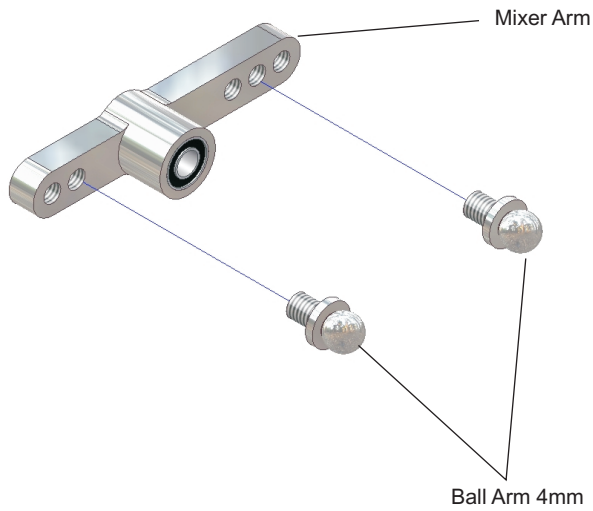

NOTE: Assemble 2 sets of this mixer arm



STEP 4-7 MAIN ROTOR HEAD ASSEMBLY

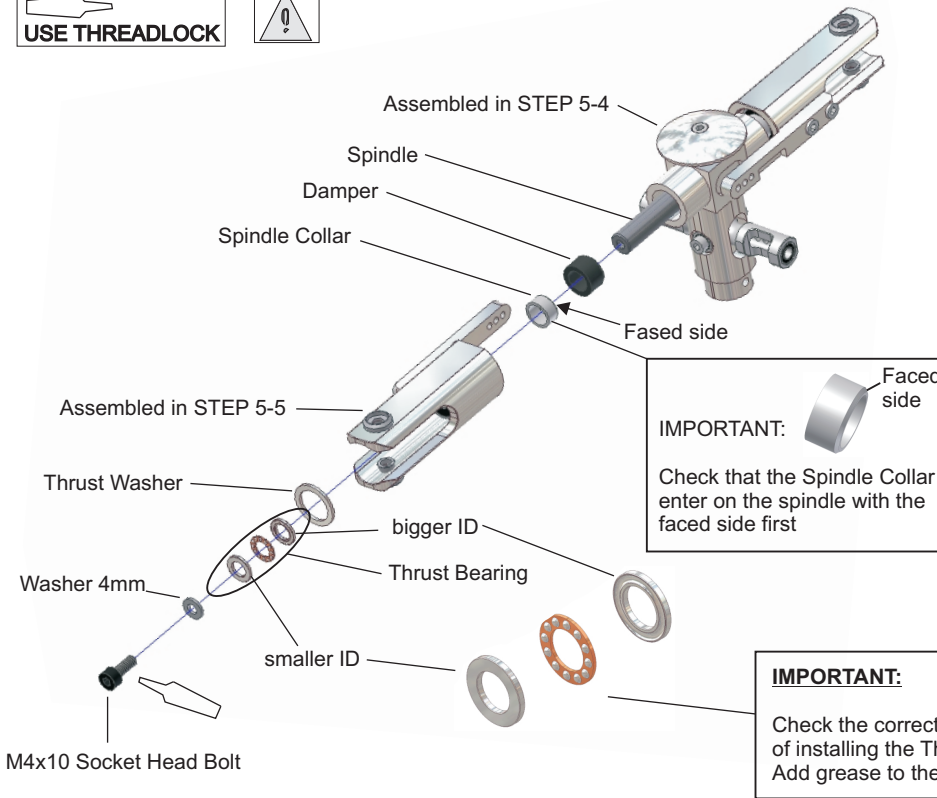

NOTE:
Use silicon grease for the dampers. This also needs to be reapplied as part of your on going maintenance (after about 30 to 40 flights) to ensure that the dampers not getting dry.

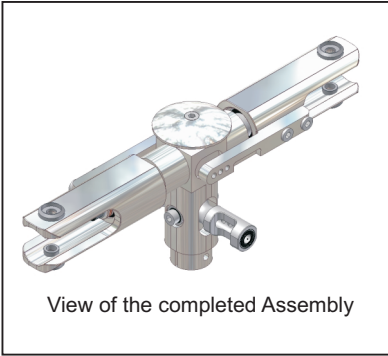

STEP 4-8 MAIN ROTOR HEAD ASSEMBLY

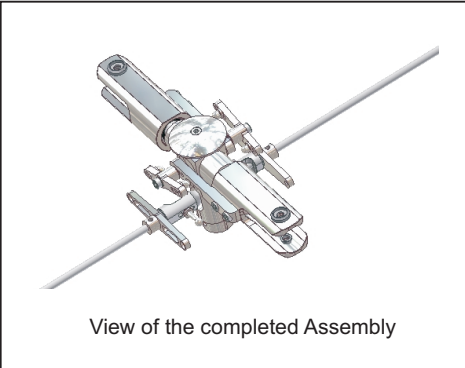
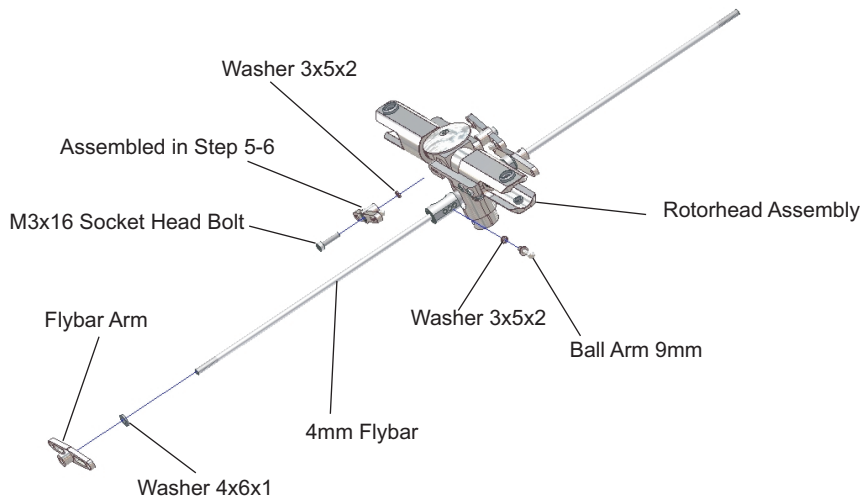

NOTE:
Assemble both sides of the Rotor head the same way. Do NOT use threadlock for later adjustments.

STEP 4-9 MAIN ROTOR HEAD ASSEMBLY

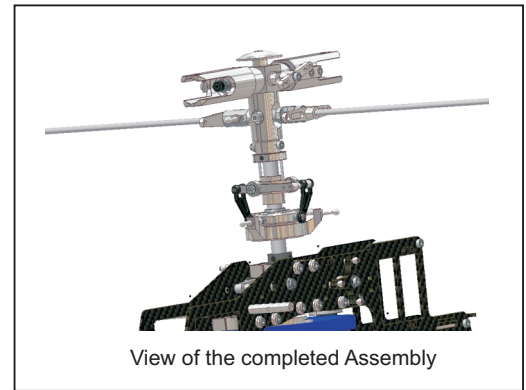
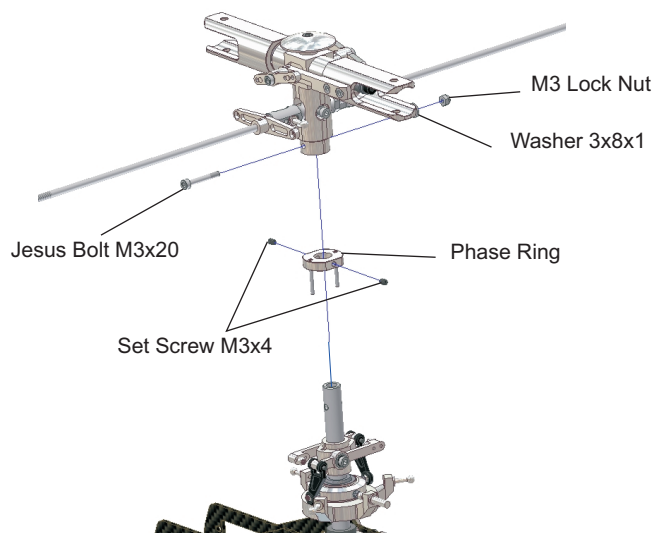

STEP 4-10 SWASH GUIDE ASSEMBLY

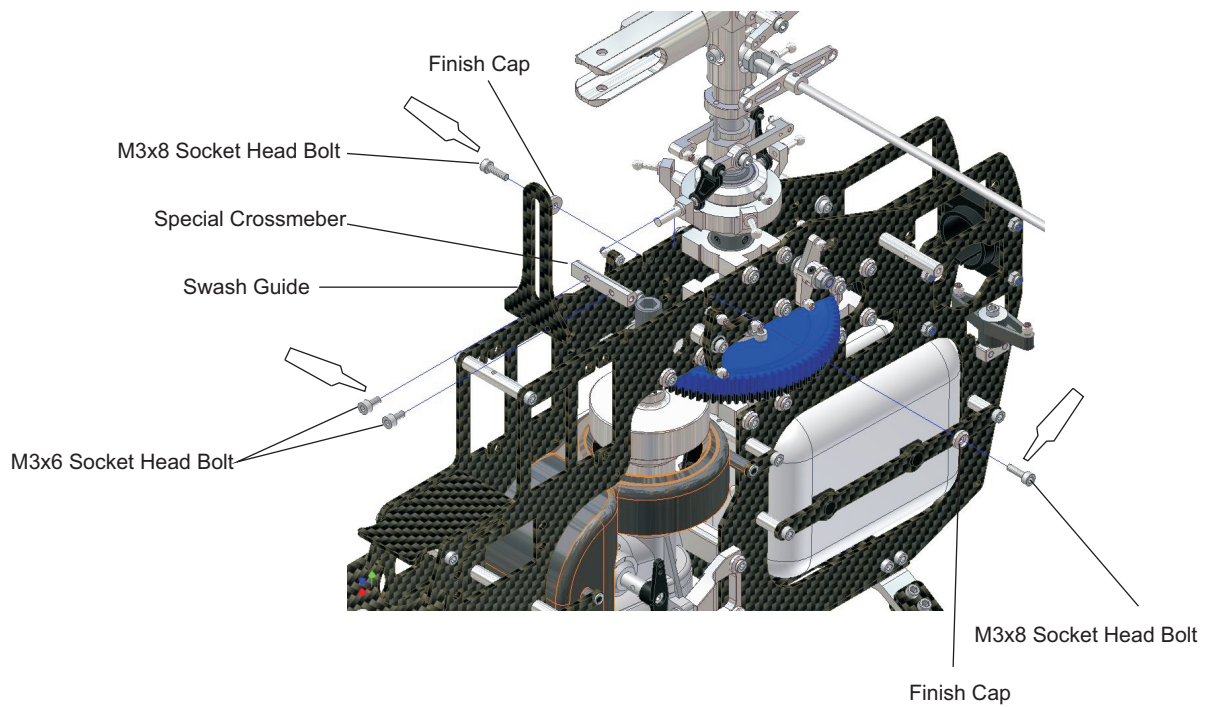

STEP 4-11 CONTROL ROD INSTALLATION



NOTE:
 Assembly both sides of the flybar control arm on the same way

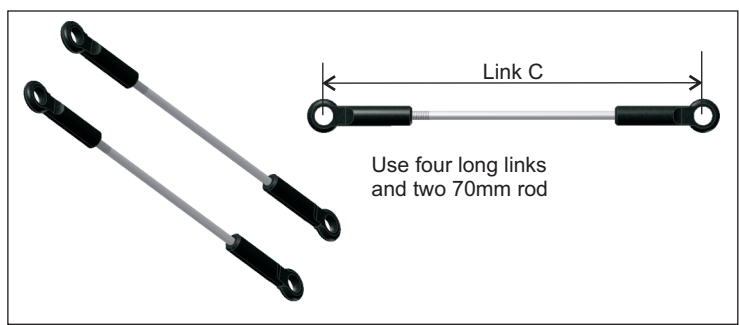
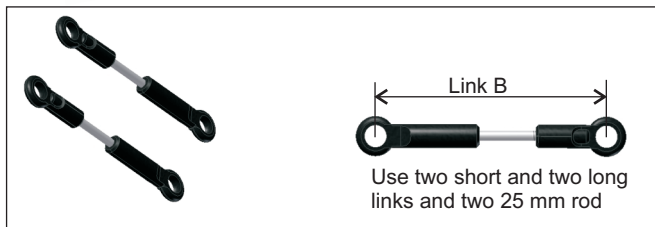
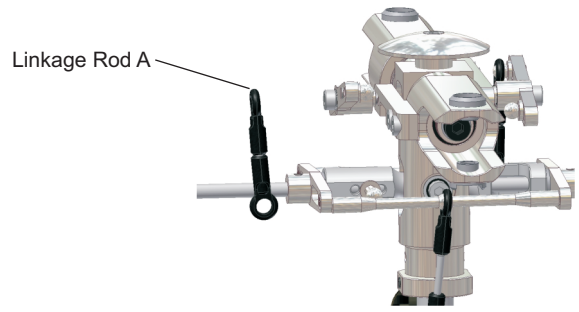
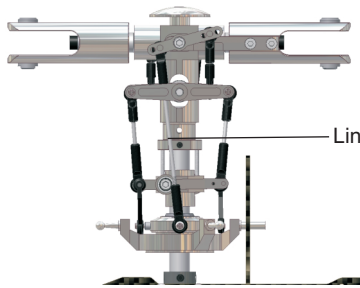
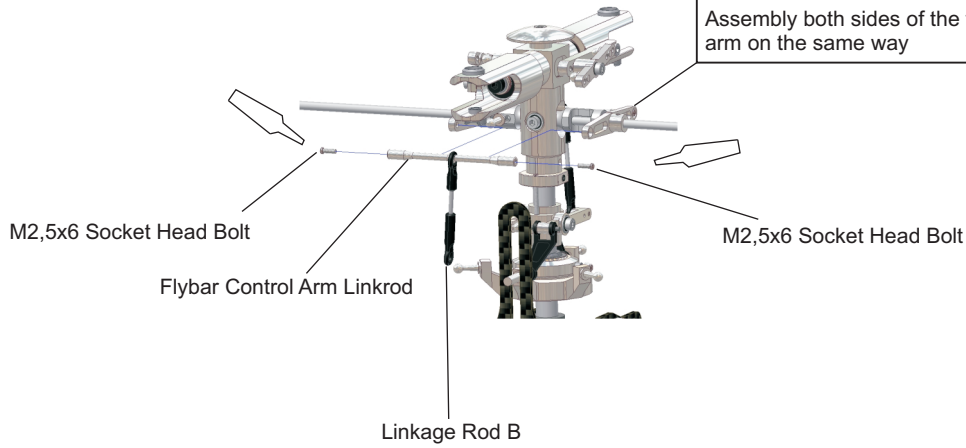

NOTE:

The size of the linkage rod can variate depending on the head setup. In the STEP 7-2 will be an example of setup with the acording sizes of the linkage rods.

By looking closely, you will notice on the universal links the letters RJX (on the small) and RJXHOBBY on the large links. ensure this are always pointed outside from the ball as shown in the diagram below.



STEP 4-12 MAIN ROTOR HEAD ASSEMBLY



IMPORTANT:
 Insure the correct direction of the Flybar Paddle.

Ensure the two M3x3 Sets Screws are on the D-Cut of the Flybar.

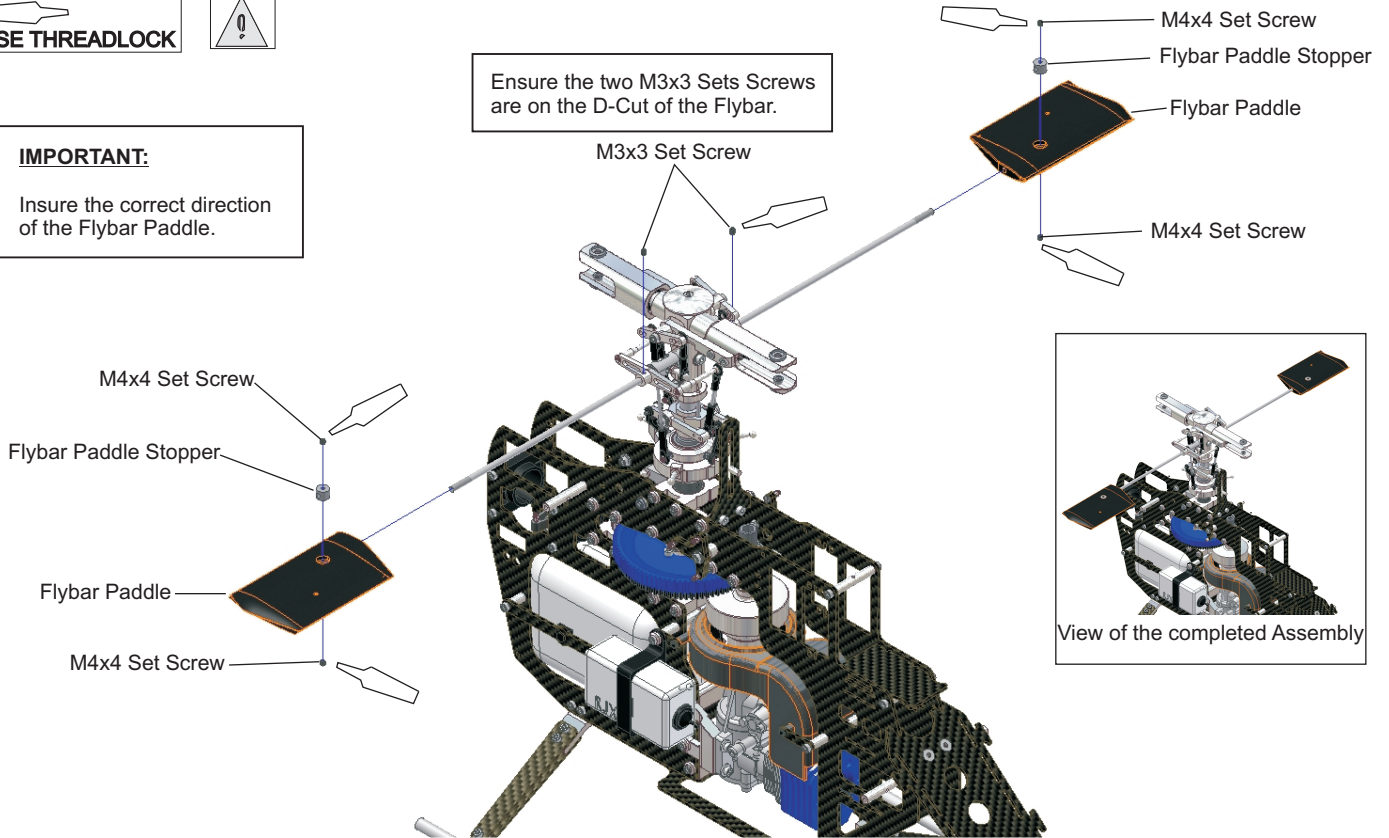

NOTE:
 Adjust so that A and B are exactly the same distance and secure with the M3x3 Set Screws firmly.

IMPORTANT:
 Center the flybar in the seesaw firmly before securing the control arm. Check to be sure that there is no sideplay in the flybar before securing the control arm. Ensure that the finished assembly moves freely in all axis.

STEP 5-1 TAILCASE ASSEMBLY

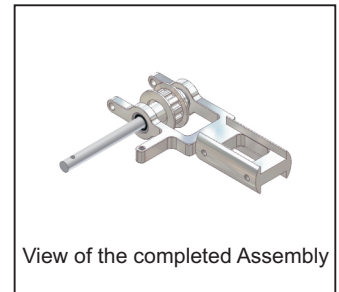
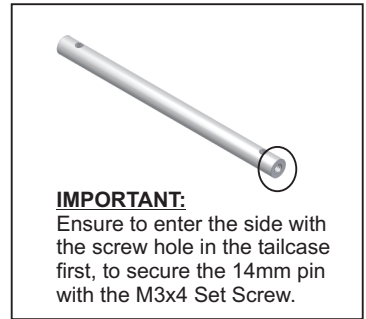
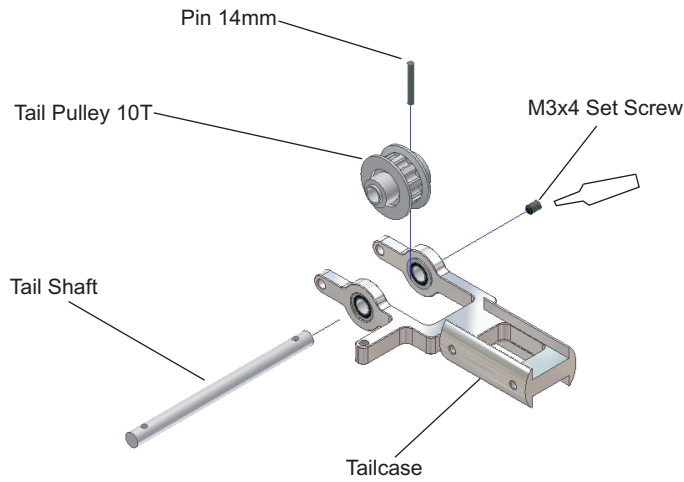

STEP 5-2 TAILCASE ASSEMBLY

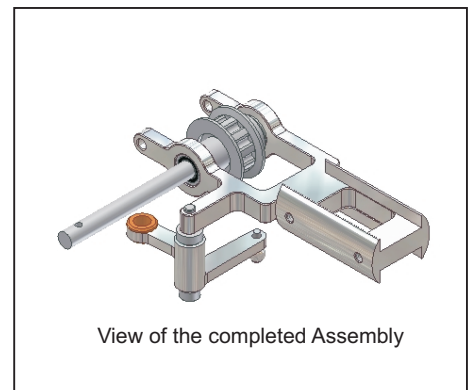
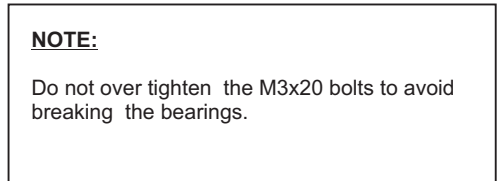
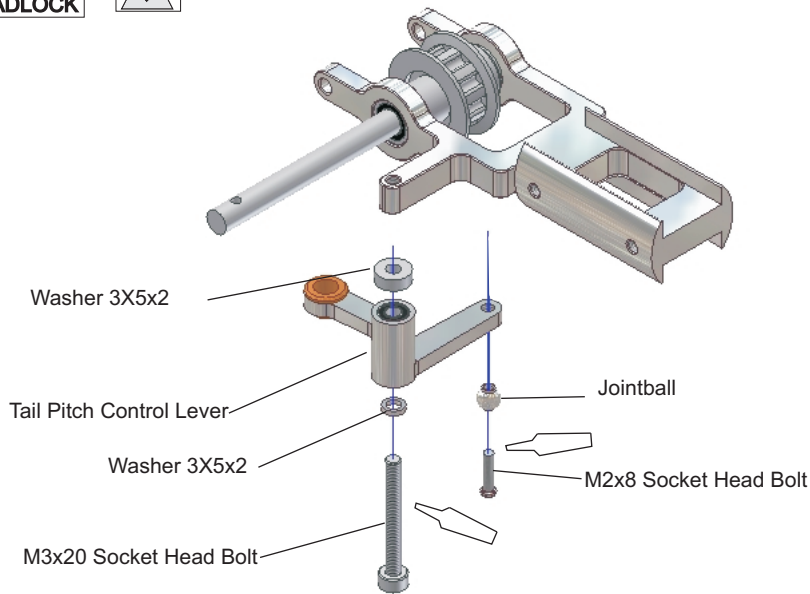

STEP 5-3 TAILCASE ASSEMBLY

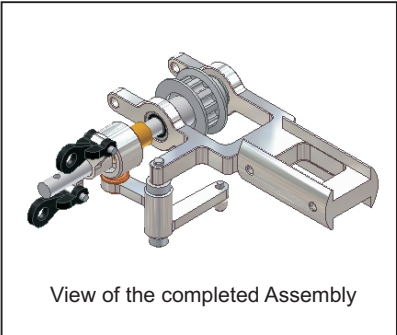
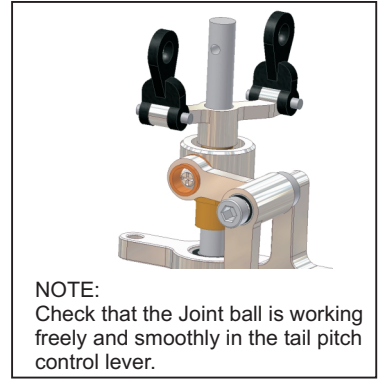
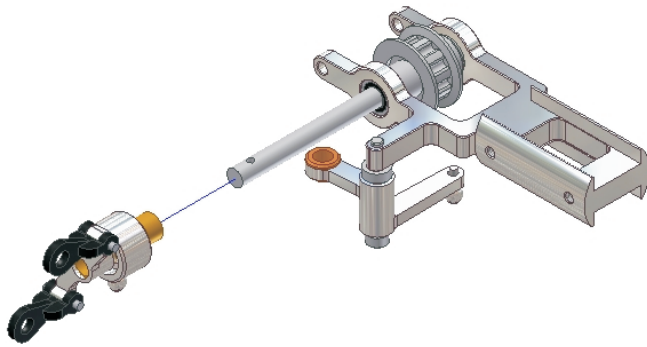

STEP 5-4 TAILCASE ASSEMBLY

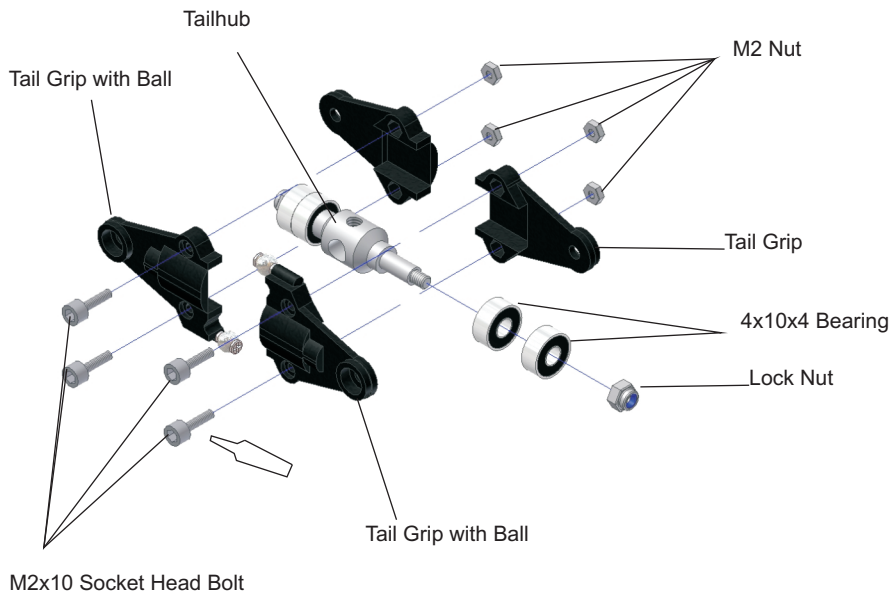

NOTE:
Do NOT over tighten the M2x10 Socket Head Bolt to avoid damaging the plastic grips.



STEP 5-5 TAILCASE ASSEMBLY

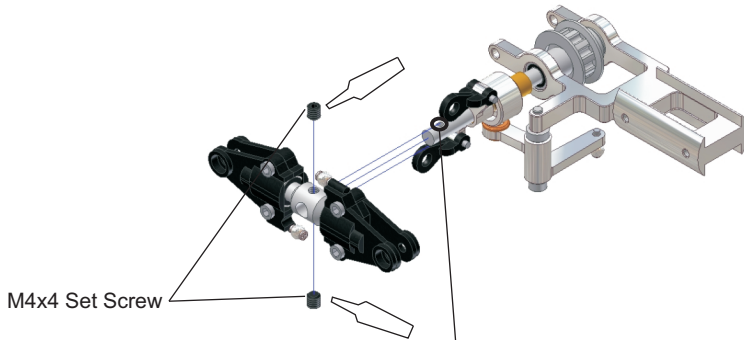

IMPORTANT:
Fix the two M4x4 Set Screw into the holes from the tailshaft.

NOTE:
Clip the linkage into the jointball and check that the assembly works smooth.

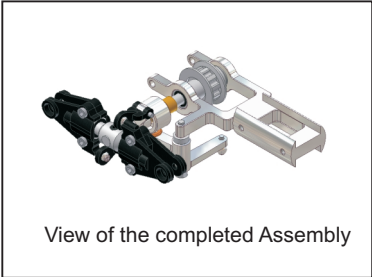

STEP 5-6 TAILCASE ASSEMBLY

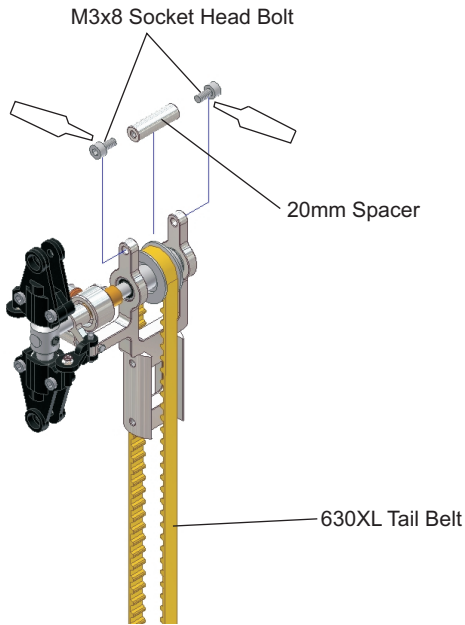

STEP 5-7 TAILCASE ASSEMBLY

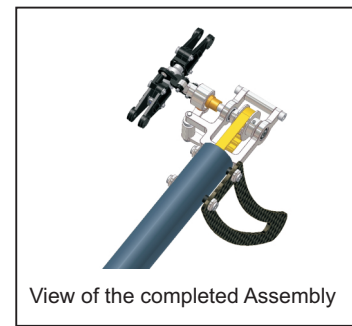
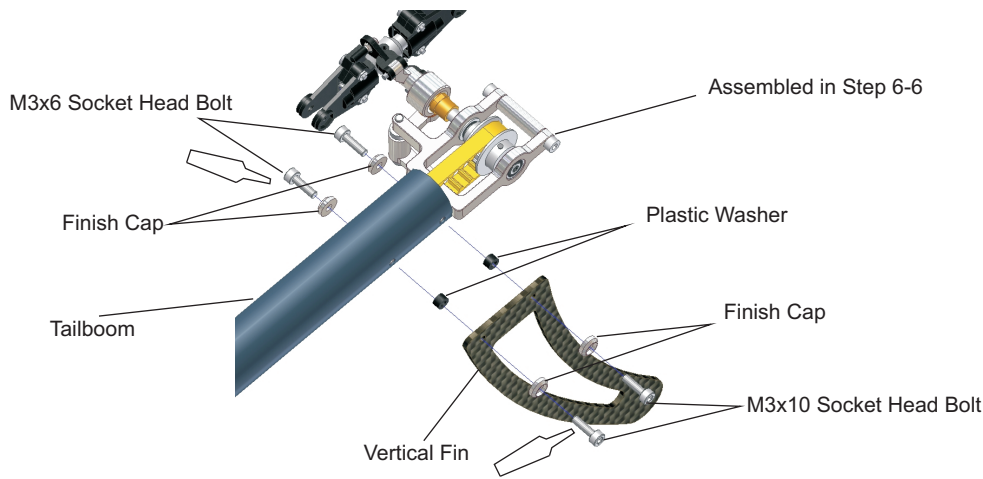

STEP 5-8 TAIL BOOM INSTALATION

NOTE:

Introduce the complete Tail Assembly into the Tail Boom Holder as shown in the diagram. Next .The Tail Rotor is pointing upwards, place the tail belt on the Front Pulley and check the Tail Belt is not twisted. Pull back and turn the complete Tail Assembly 90° clockwise and tighten slightly the four M3x40 Socket Head Bolts and the M3 Locknut.

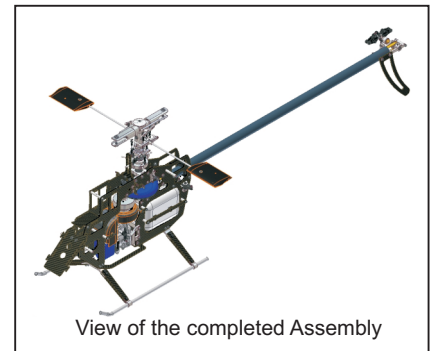
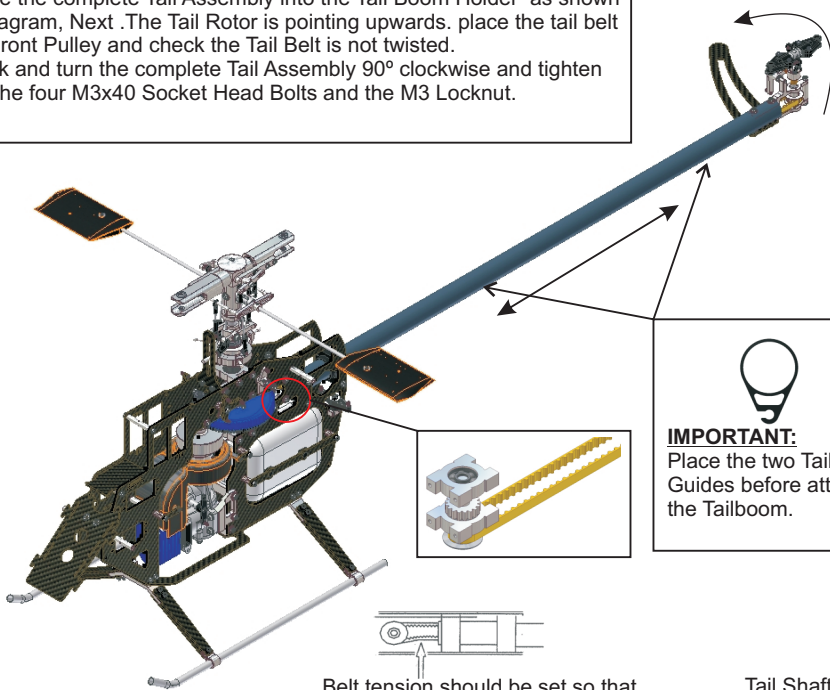

IMPORTANT:
Place the two Tail Rod Guides before attaching the Tailboom.

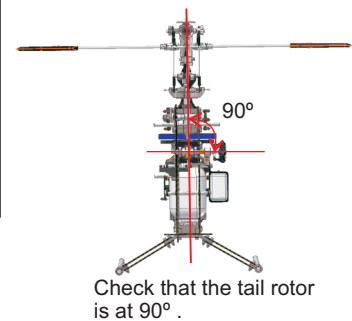

Belt tension should be set so that when pressing with you finger, the sides of the belt do not come in contact with each other. If unsure is always better to set the belt tension too tight rather than too loose. Tighten up the M3x40 after adjusting the tension.

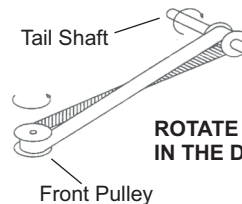

ROTATE THE DRIVE BELT IN THE DIRECTION AS SHOWN.

STEP 5-9 TAIL BRACE ASSEMBLY

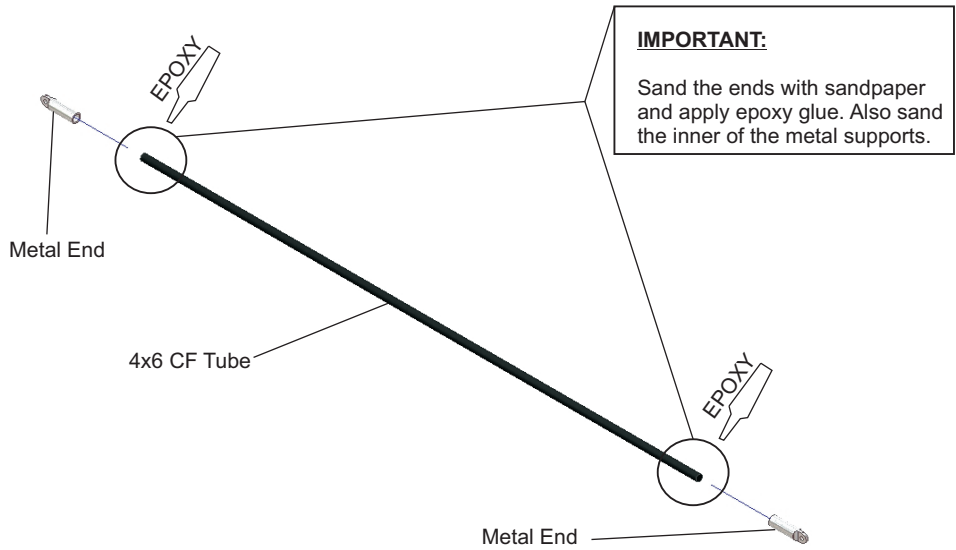

IMPORTANT:
Sand the ends with sandpaper and apply epoxy glue. Also sand the inner of the metal supports.

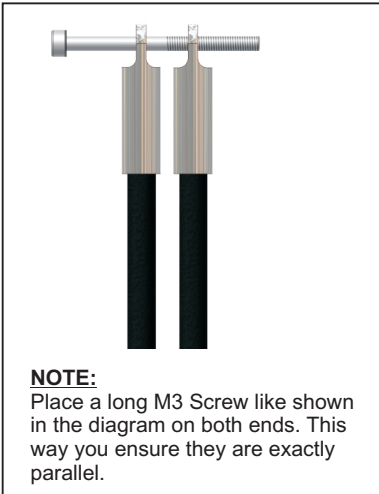

NOTE:
Place a long M3 Screw like shown in the diagram on both ends. This way you ensure they are exactly parallel.

Assembly to sets of the Tail Brace

STEP 5-10 TAIL BRACE ASSEMBLY

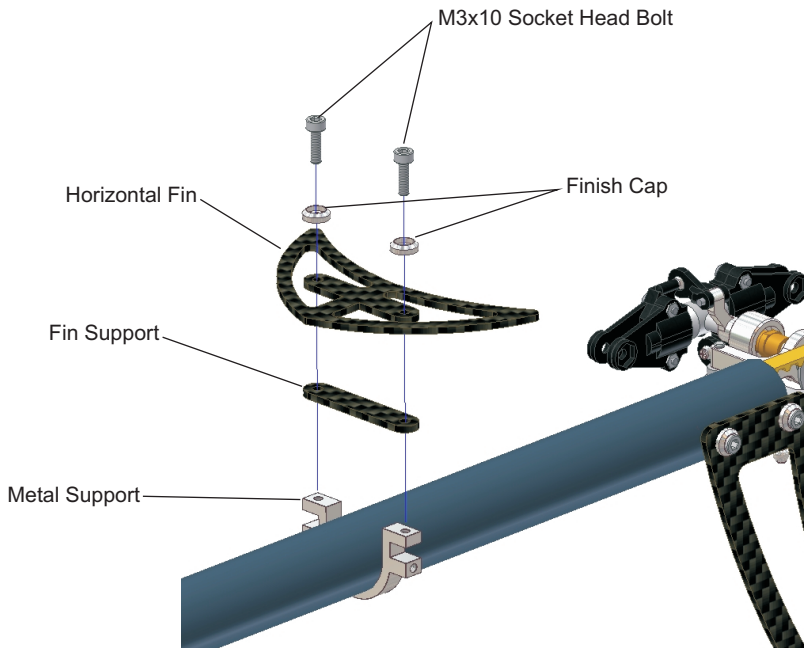

NOTE:
Do NOT yet tighten the M3x10 Socket Head Bolt. There will adjustments hended later with the Tail Brace.



View of the completed Assembly

STEP 5-11 TAIL BRACE INSTALLATION

 **USE THREADLOCK**

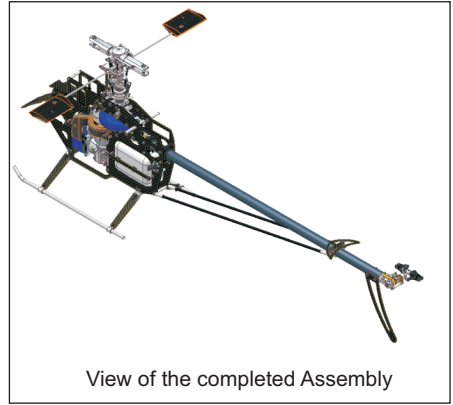
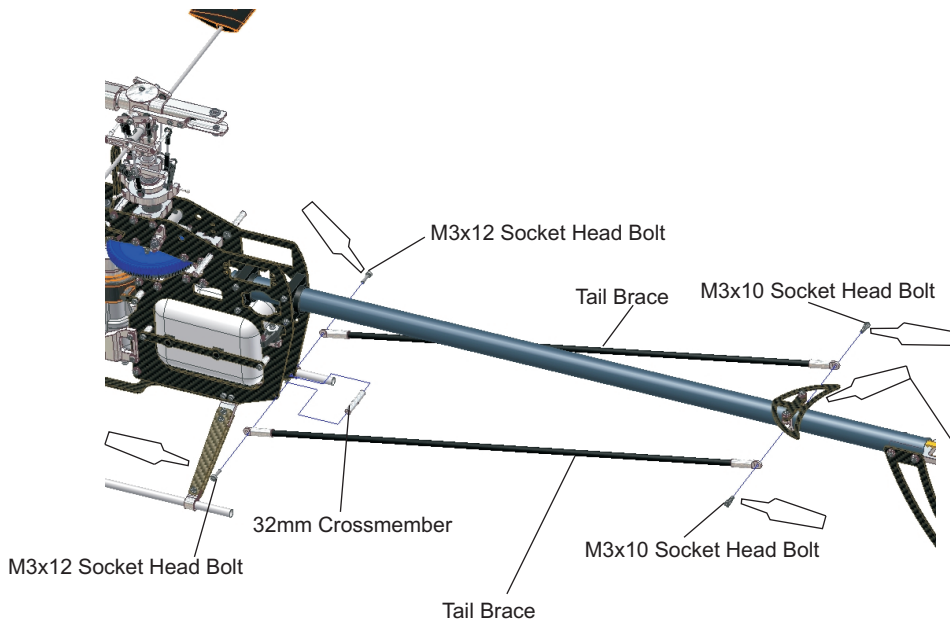

NOTE:
Fix the two M3x10 Socket Head bolt form the Horizontal Fin with Threadlock in this Step

STEP 5-12 TAIL CONTROL ROD ASSEMBLY

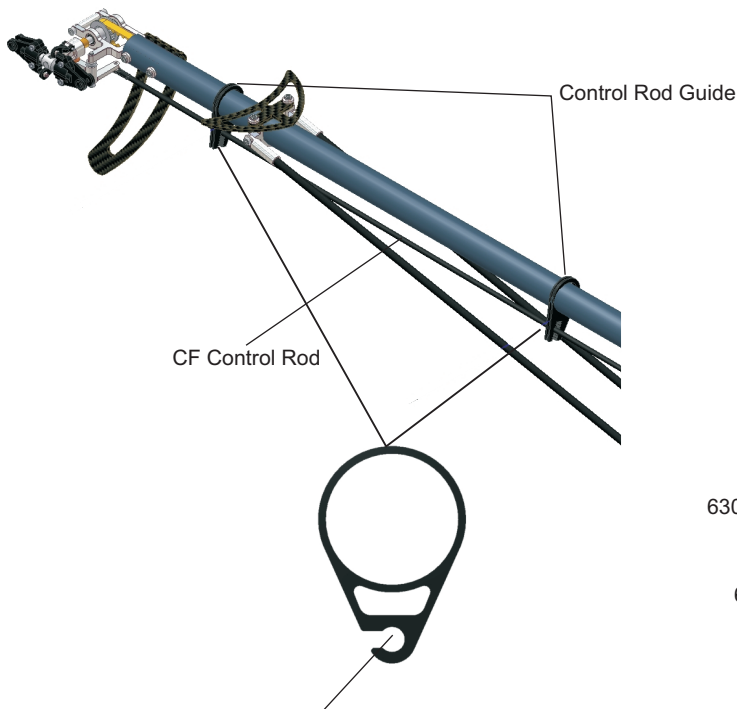

NOTE: Assembly bot side of the CF Control Rod

NOTE:
The Sleeve has do diferent inner diameter. The smaller ID is glued onto the CF Rod. Cut from the Linkage the Logo with a knife to ensure a easy adjustment of the rod lenght.

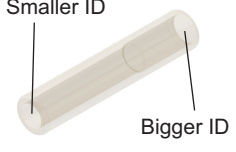
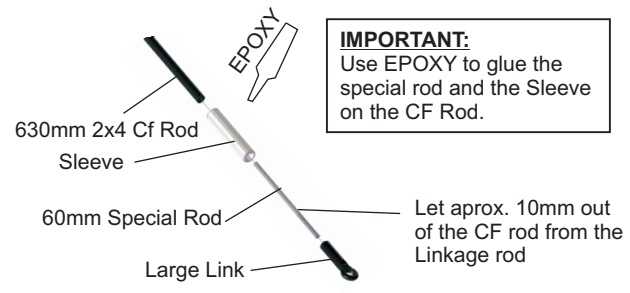
NOTE:
Place a short peace of heatshrink on the CF Rod where the CF Guide touch the CF Rod, to avoid the CF Rod wear out.

For easy install of the Guide, heat up the Guide with a lighter and push it over the Tailboom.

STEP 6-1 SERVO INSTALLATION

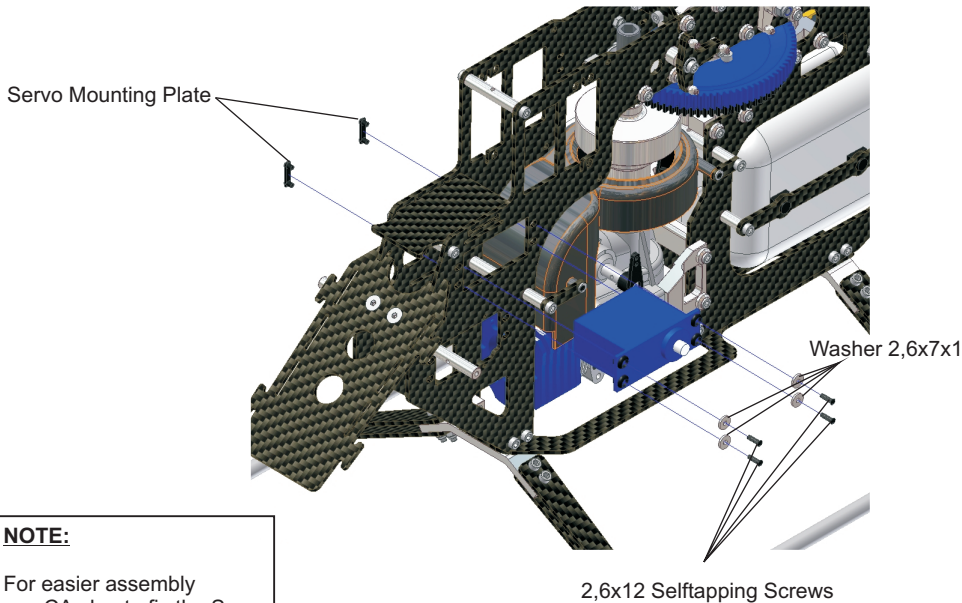

NOTE:
For easier assembly use CA glue to fix the Servo Mounting Plates before installing the servo.

STEP 6-2 SERVO INSTALLATION

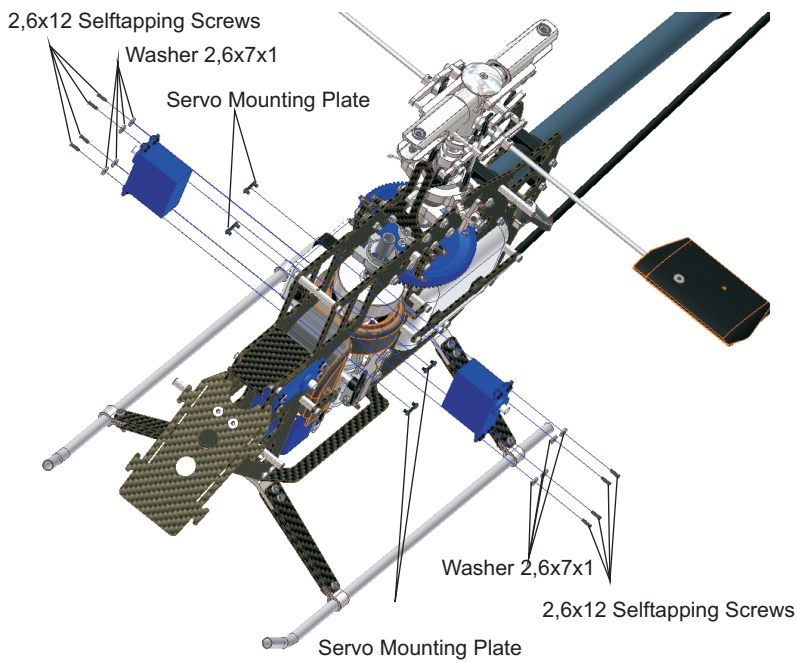

NOTE:
For easier assembly use CA glue to fix the Servo Mounting Plates before installing the servo.

IMPORTANT:
Depending on servo type used for cyclic, you have to install the servo from inside the frames. When installing from outside the servo horn may touch the canopy. In the diagram below you see how to insert the servo into the frames.

1. Attach the servo mounting plate into the grommets from the servo.



2. Steps to follow to inserting the servo.

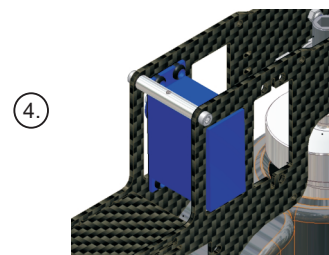
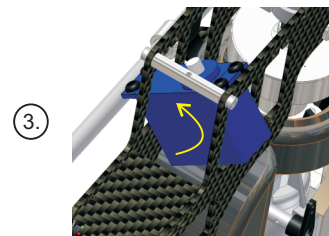
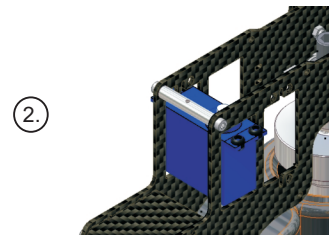
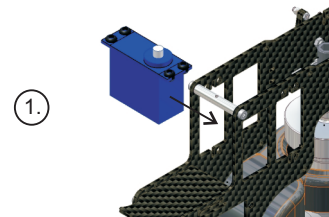

When you have the servo in this position fix it with the four Selftapping Screws and Washers as shown on the left.

STEP 6-3 SERVO INSTALLATION

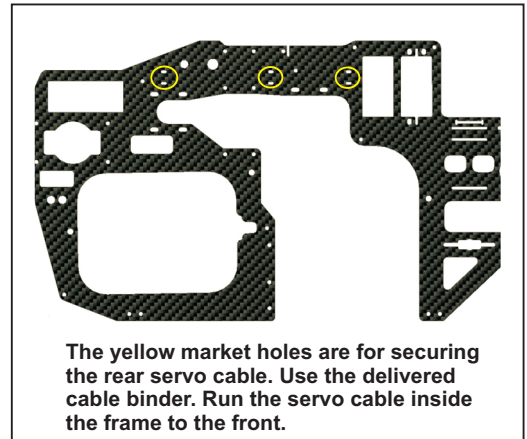
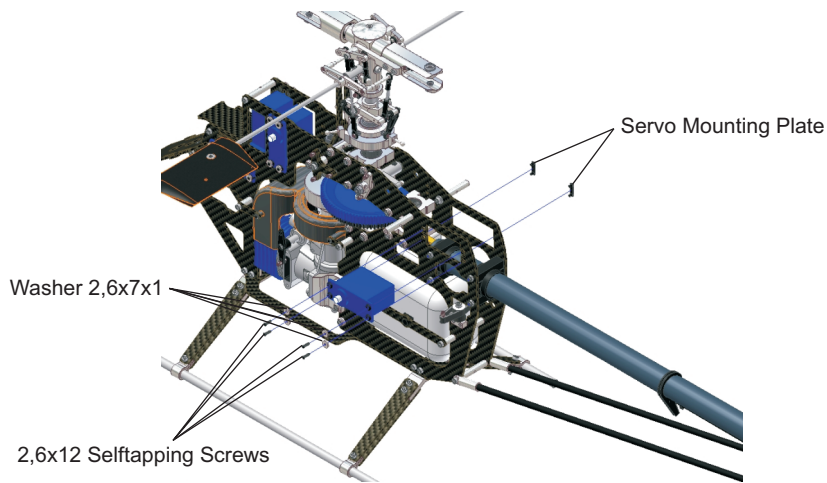

NOTE:
For more easier assembly use CA glue to fix the Servo Mounting Plates before installing the servo.

IMPORTANT:
Depending on servo type used you have to install the servo from inside the frames shown in STEP 7-1.

STEP 6-4 SERVO INSTALLATION

NOTE:
For more easier assembly use CA glue to fix the Servo Mounting Plates before installing the servo.

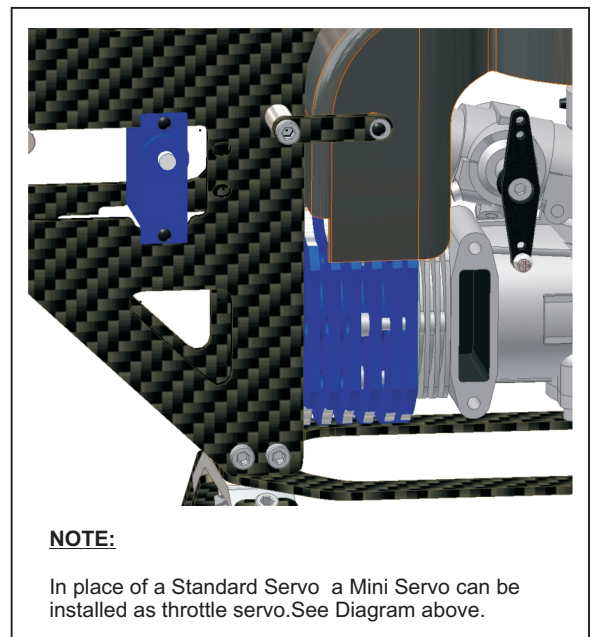
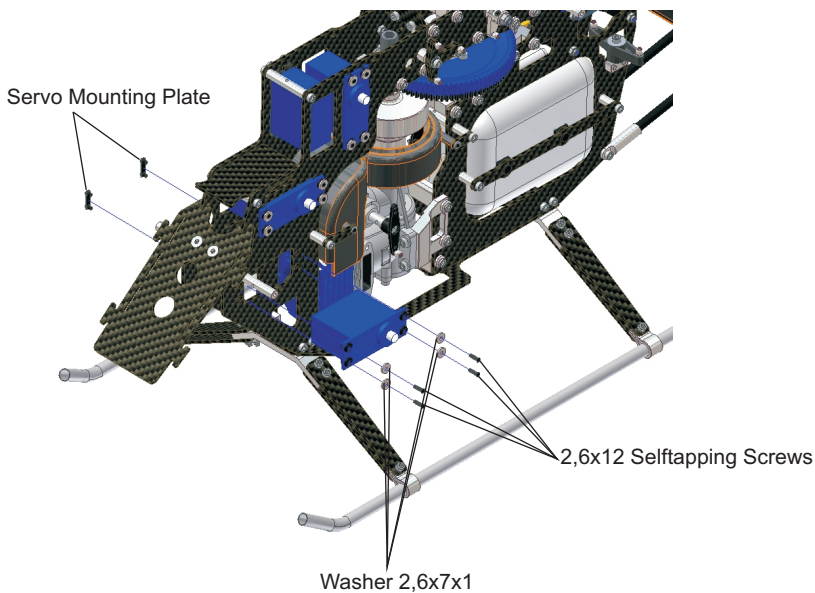

STEP 6-5 RECEIVER / GYRO / BATTERY INSTALLATION

- ① Install the Battery and Receiver
- ② and ③ Install the Gyro sensor

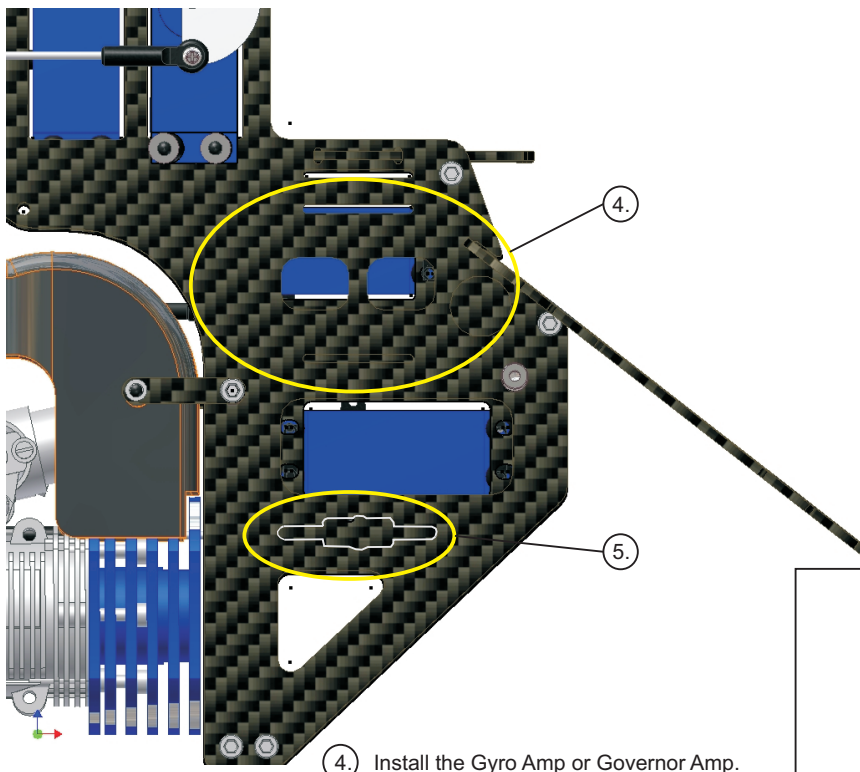
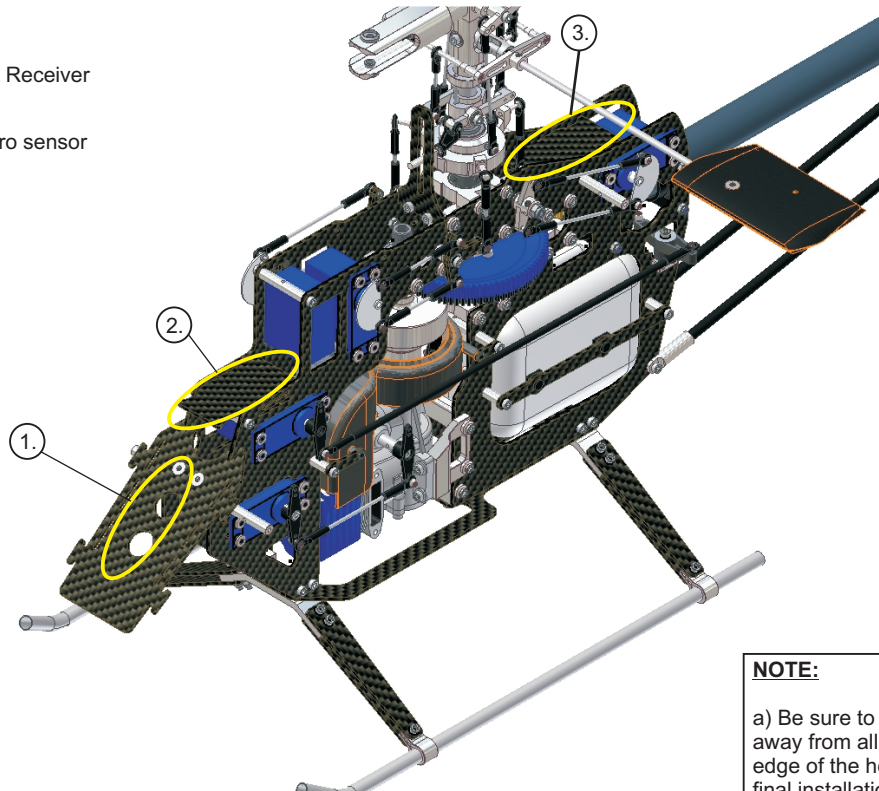

- ④ Install the Gyro Amp or Governor Amp.
- ⑤ Install the the Switch harness

NOTE:

a) Be sure to keep all the lead wires, etc., away from all servo arms, rods and sharp edge of the helicopter mechanics. After final installation group these wires together.

b) It is suggested that both the receiver and gyro amplifier be isolate from vibration by wrapping them in foam, then securing them to the model using double-sided adhesive tape.

c) Be sure when installing the gyro to the gyro mounting plate that it does not come in contact with the frame of the helicopter and that the mounting surfaces are free from all, residue, etc. Clean if necessary to ensure proper adhesion. There are cutouts in the frame to secure the gyro sensor with hook and loop tape.

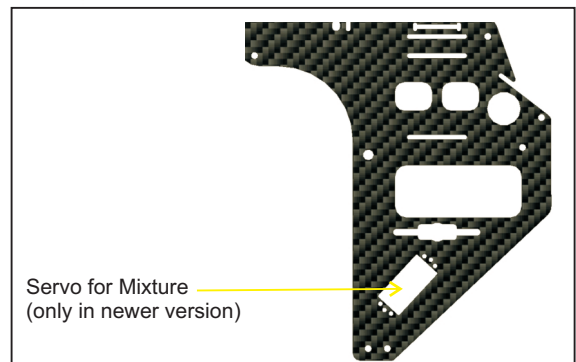

STEP 6-6 SERVO ARM PREPARATION AND INSTALLATION

NOTE:



Before attaching any of the servo output arms, turn on your radio and check that all of the primary control functions and trims are set to neutral. Pay special attention to the throttle/pitch channel where the stick has to be positioned manually unless your transmitter has a digital or graphical display of the output. If you have this feature, set the stick to give a read out of 50%. If you do not have this feature you will need to set the stick to the neutral position by eye. If you also have hovering pitch and throttle trim knobs, these should also be set to their mid positions to give equal amounts of +/- output. Once you have done this, all of the servos should be at their mid points and have equal amounts of rotation in both directions.

Initial set up can now begin.

Choose the thickest output arms/discs that you have, and that can accommodate the joint balls at a radius of 13.5mm each. For the left/right servos try the disc/arm on the output shaft until you find a position where a suitably spaced pair of holes sits closest to the centre line of the servo case. For the front servo, imagine a rectangle whose four corners sit on the four joint balls making up this linkage. The holes in the disc/arm should sit on the line that forms the short end of this rectangle. Please refer to the diagram again for clarification.

If you cannot find an exact position use the one nearest and make minor adjustments with the appropriate sub trim and not the main trim.

Remove the disc/arms one at a time and noting which side the joint balls fit, attach them as shown. Also note the use of spacers under the joint balls fitted to the left/right servo discs/arms.

Cut off the excess material or unused arms as shown and refit the finished disk/arm in its original position. Fix securely with the screw that came with the servo.

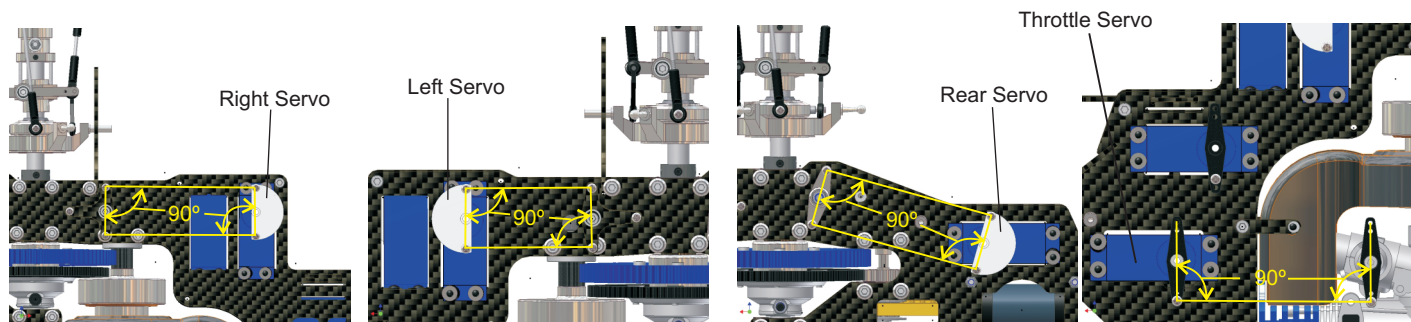
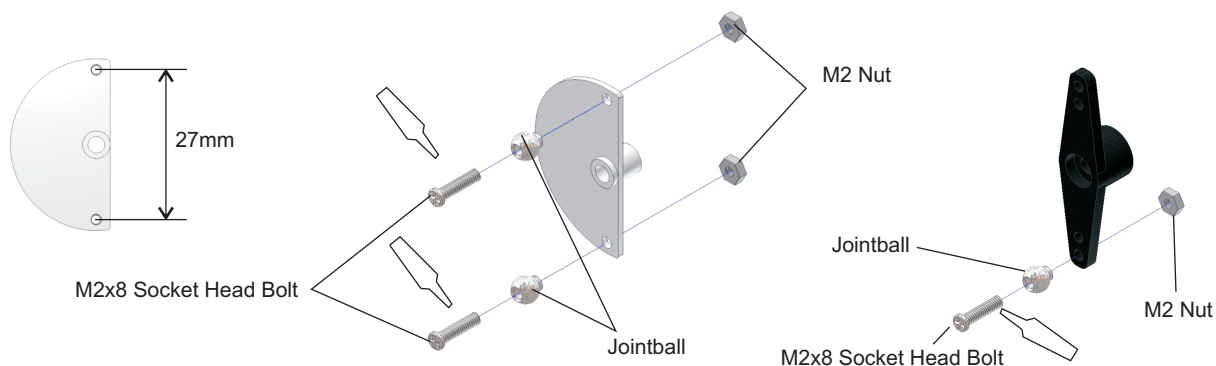

IMPORTANT:

Be sure that all arms are 90° and parallel to each other like shown in the diagrams above.

1. Attach the jointball to the servo horns on the left,right,rear,throttle (ensure the carburator is at 50% opened, if not adjust the throttle arm on the carburator) and tail servo as shown in the diagram above.
2. Mount the servo horns firmly with the screw included in the servo. Use threadlock on servos with metal gears to secure the screws.
3. Be sure to connect the servos according your transmitter manual.
4. Make sure all servo horns are positioned as shown above. If the servo horn is not parallel as shown, minor centering adjustments can be made using the radio's subtrim.

STEP 6-7 LINKAGE CONNECTION

NOTE: Assemble the linkage as shown below
Check the correct side of the link with the logo.

1. RIGHT SERVO

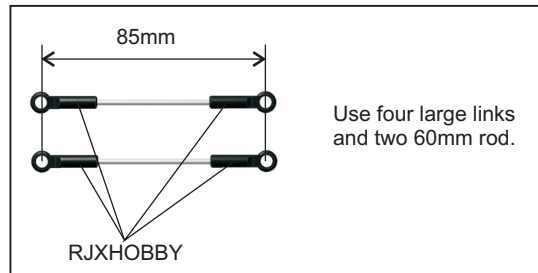
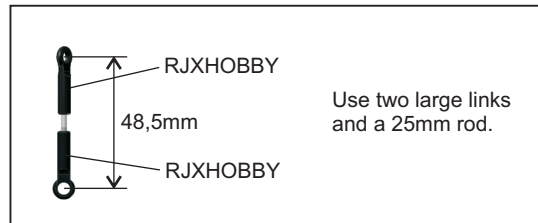
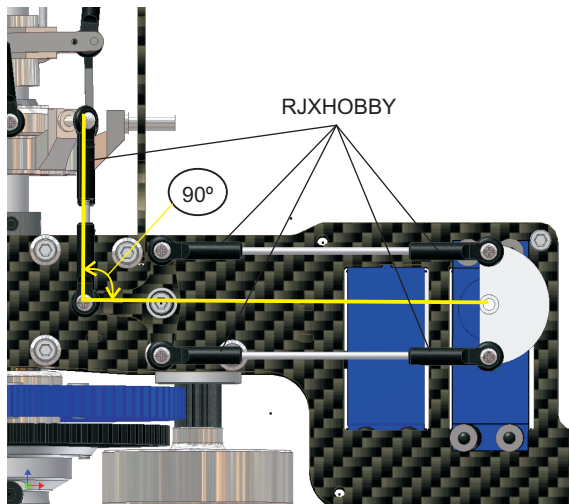

2. LEFT SERVO

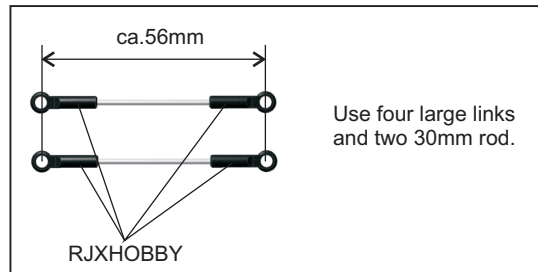
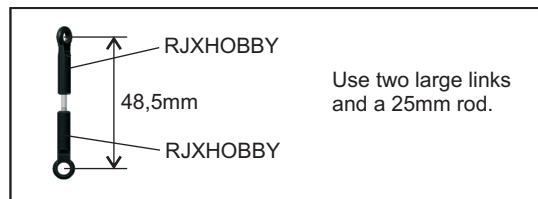
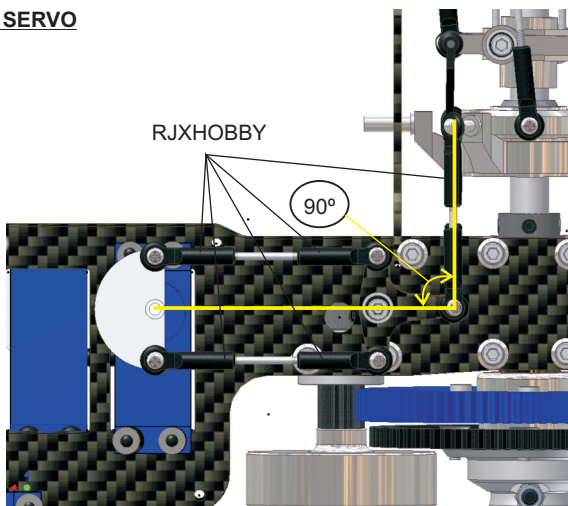

3. REAR SERVO

IMPORTANT:
Secure the two M4x4 Set Screws from the Nick Lever with threadlock.

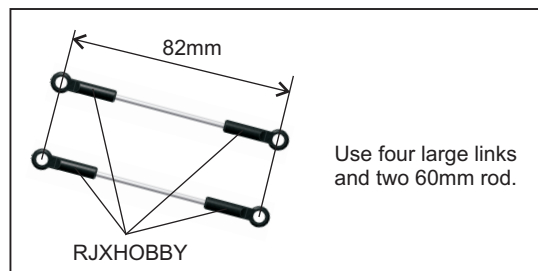
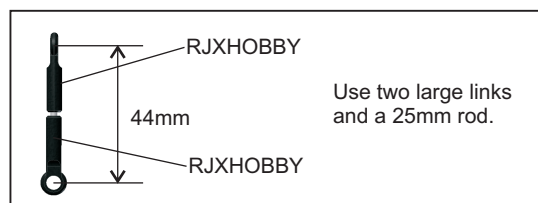
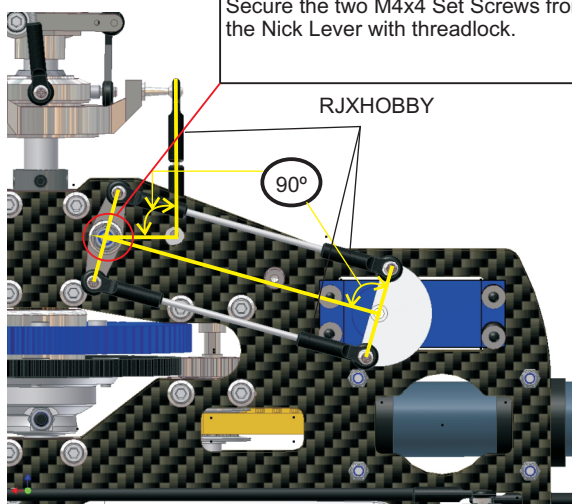

STEP 6-8 LINKAGE CONNECTION

4. THROTTLE SERVO

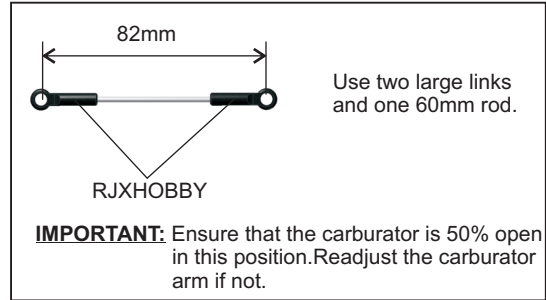
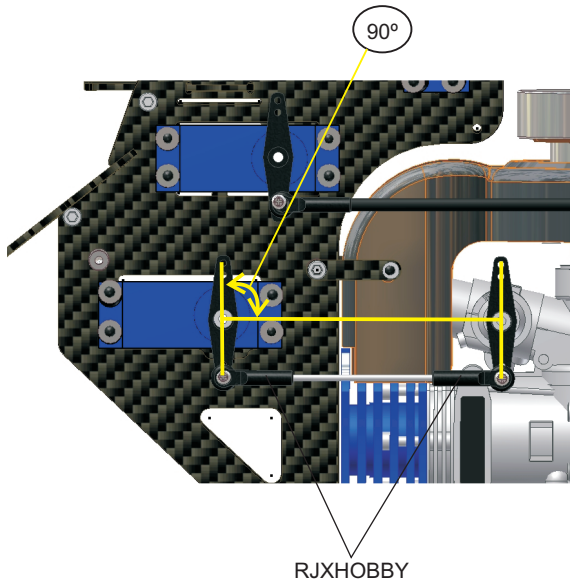

NOTE:

To avoid differential throttle travel, make certain both the throttle arm and the servo horn are positioned as shown next in the diagram.

To achieve the correct position of the throttle/servo arm, it may be necessary to re-position the arm on the carburator and adjust the length of the throttle linkage slightly to achieve full open and close positions. It may be necessary to increase/decrease the travel of the throttle servo through the ATV function in your radio. If this is used, make sure that the values for the high and low positions remain equal. If these values are not equal, this will create a differential or uneven movement of the throttle, making adjustment and fine tuning difficult.

5. TAIL SERVO

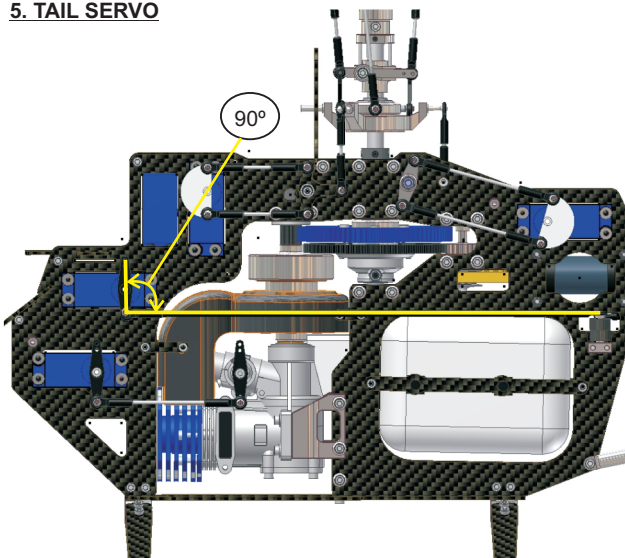

NOTE: Assembly bot side of the CF Control Rod

NOTE:

The Sleeve has do diferent inner diameter. The smaller ID is glued onto the CF Rod. Cut from the Linkage the Logo with a knife to ensure a easy adjustment of the rod lenght.

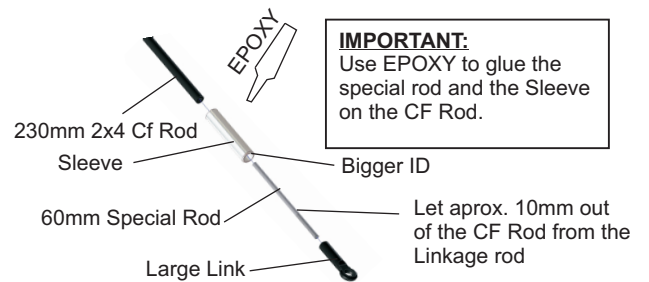

Use two large links and the 230mm CF Rod

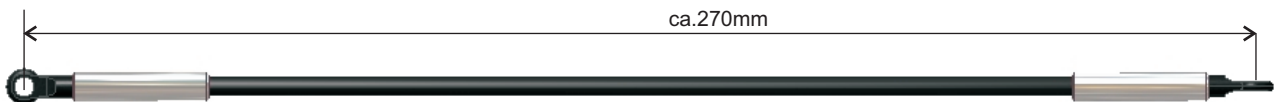

STEP 7-1 ROTOR HEAD SETUP

In the diagrams below are explained the different settings possibilities of this rotor head. There are many setups with different results. Adjust this settings on demand of you and your capability. Some of the settings can produce binding. Ensure that the ATV settings in the radio and linkage rod adjustments allowing no bindings. This is important to achieve a good performance of the rotor head.

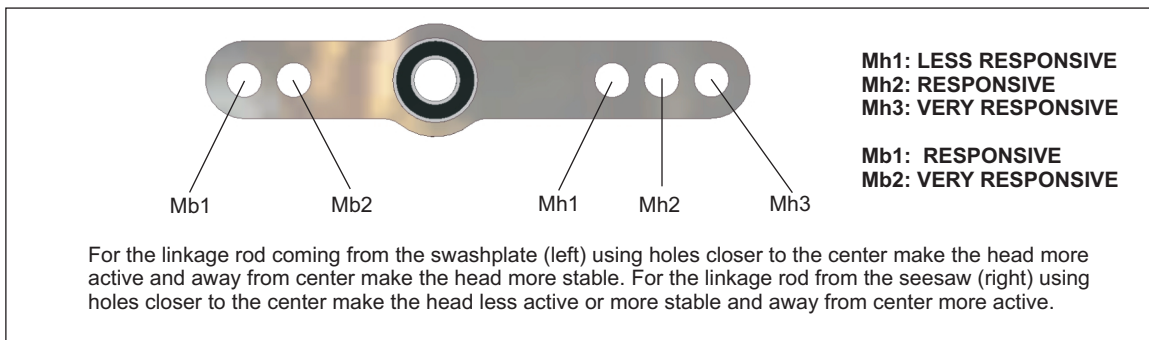
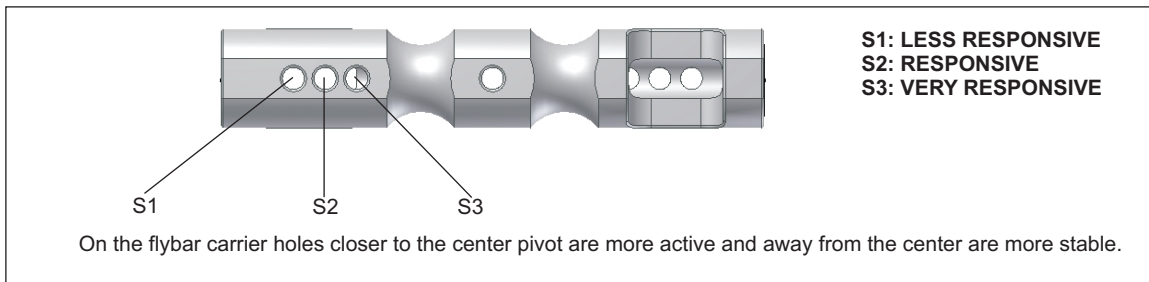
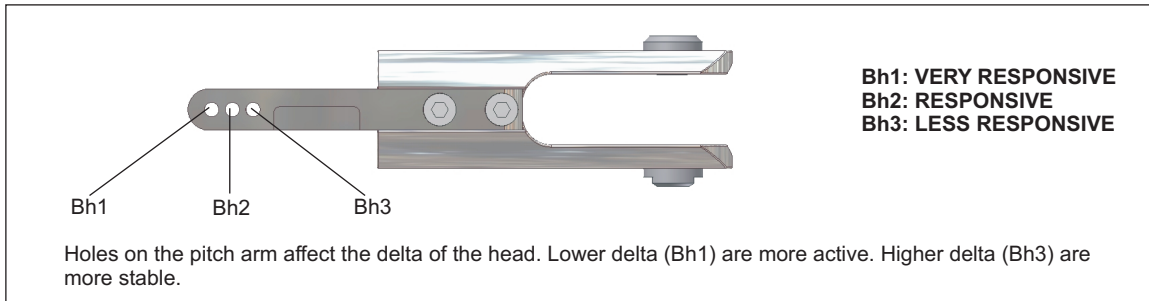

IMPORTANT:

When using very responsive settings the forces applied to the CCPM servos are higher than normal. Plastic servo gears can suffer or break. Servos with metal gears are recommended for those settings.

STEP 7-2 ROTOR HEAD SETUP

IMPORTANT: SECURE ALL JOINT BALLS AND SCREWS WITH THREADLOCK



NOTE:

In this STEP will be explained one setup of the rotor head what is good point for 3D maneuvers. There are many other settings possible. Linkage rod sizes from the rotor head are changing depending on this settings.

The size of the linkage rod is measured from center to center of the hole (see STEP 4-11).

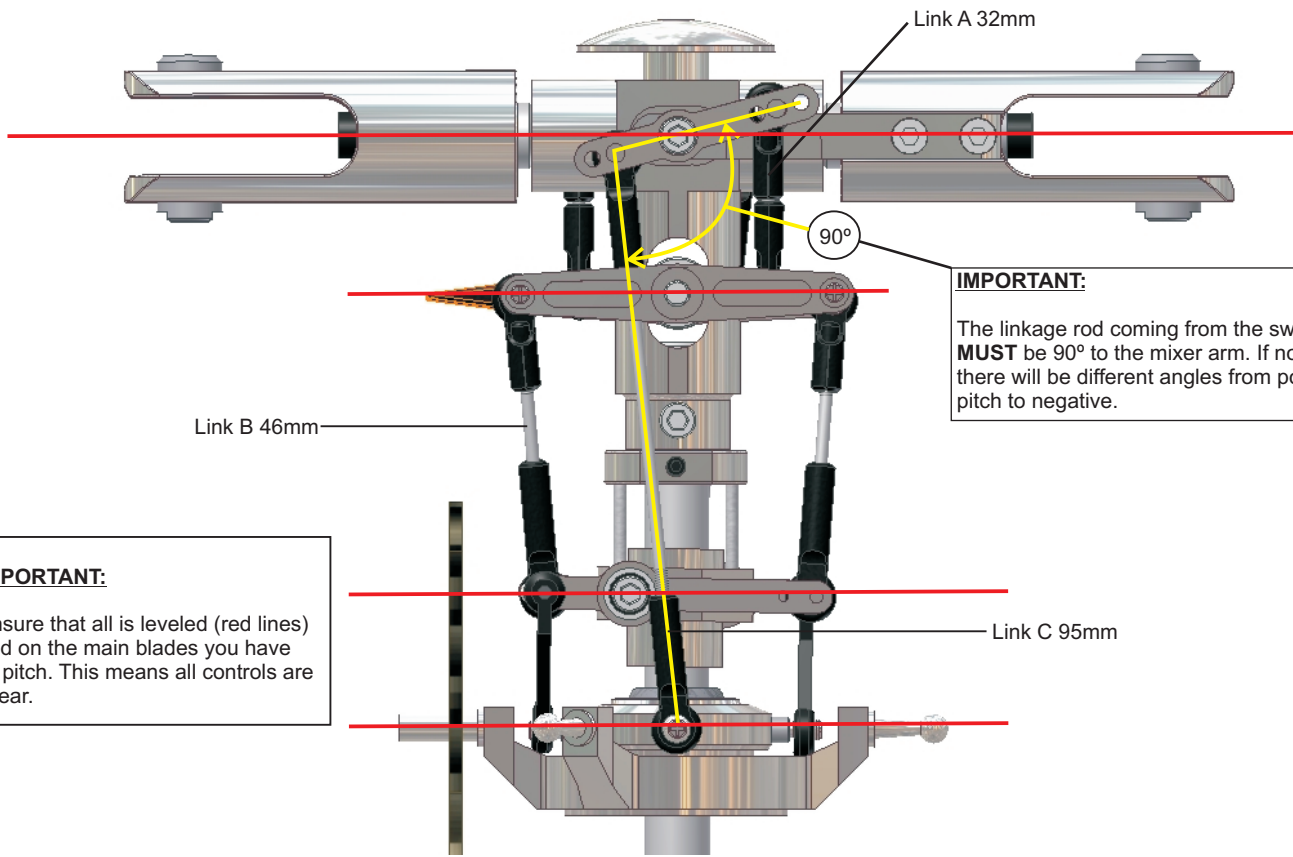

IMPORTANT:
The linkage rod coming from the swash **MUST** be 90° to the mixer arm. If not there will be different angles from positive pitch to negative.

IMPORTANT:
Ensure that all is leveled (red lines) and on the main blades you have 0° pitch. This means all controls are linear.

NOTE:
On the pitcharm is the the middle hole (Bh2) selected.

NOTE:
On the mixer arm are the holes Mb2 and Mh2 selected.

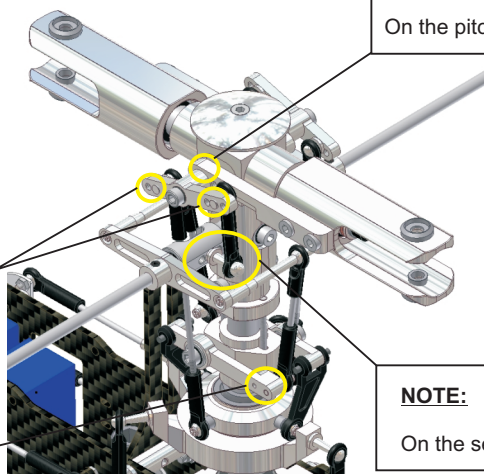

NOTE:
On the seesaw is the the middle hole (S2) selected.

NOTE:
On the washout arm the outer hole is selected.

STEP 7-3 PHASE RING ADJUSTMENT

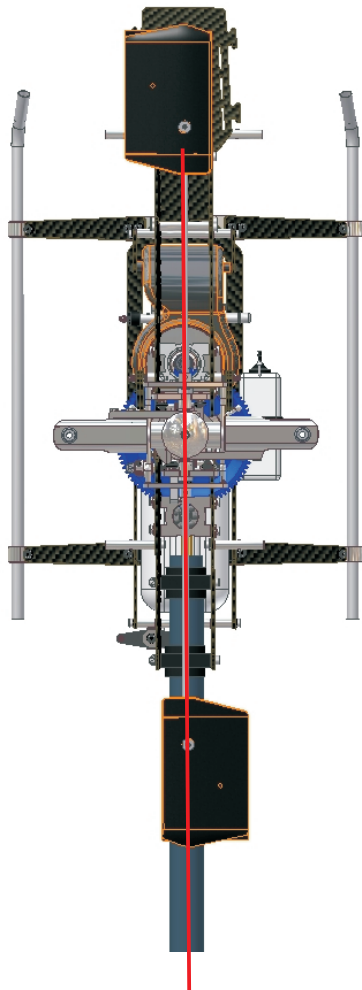

CENTER LINE OF THE HELICOPTER

NOTE:

Once the swashplate is leveled it is important to set the phasing of the washout base. This is done by rotating the rotor head until the flybar is perfectly in line with the body and the tailboom of the helicopter (see the diagram next).

The washout driver is now turned to line up the joint balls on the upper swashplate ring with the center line of the helicopter (see below) allow a small amount of clearance between the washout base and the phase ring when at full pitch. When you are satisfied tighten the phase ring to the mainshaft with the M3x4 set screws applying threadlock. Ensure to get this settings right as it will affect how the helicopter behaves in hover and when doing acrobatics.

Different adjustments can be done depending on main blades and their characteristics.

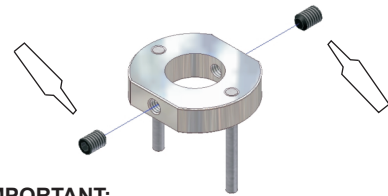

IMPORTANT:

Use threadlock to secure the M3x4 set screws

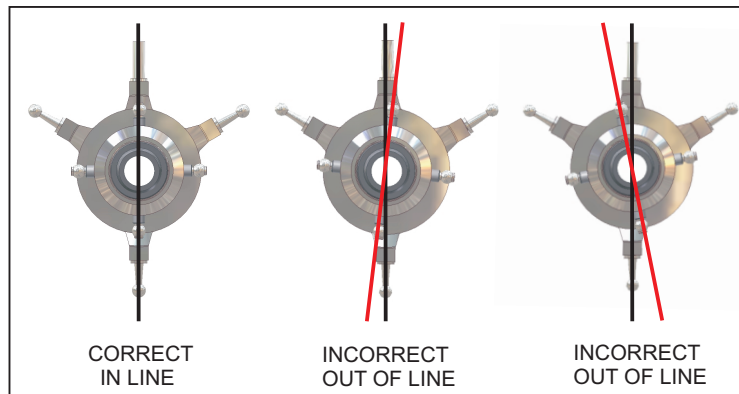

STEP 7-4 CANOPY ATTACHMENT

NOTE:

Put the rubbers grommets for about 3 min. in hot water to insert them more easier in the canopy.

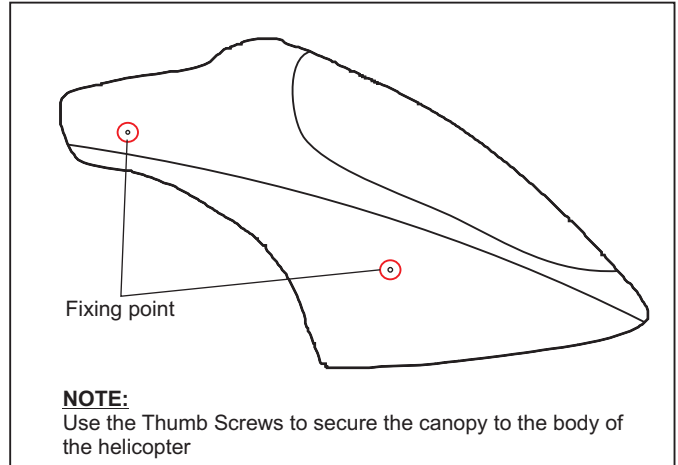
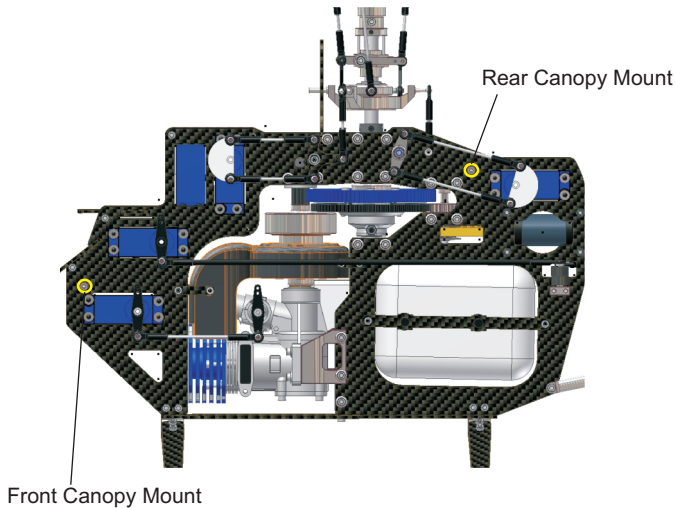

STEP 7-5 MAIN / TAIL BLADE INSTALLATION

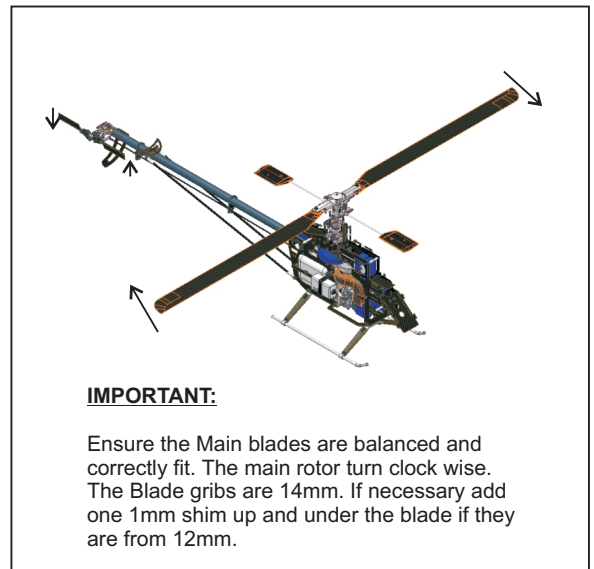
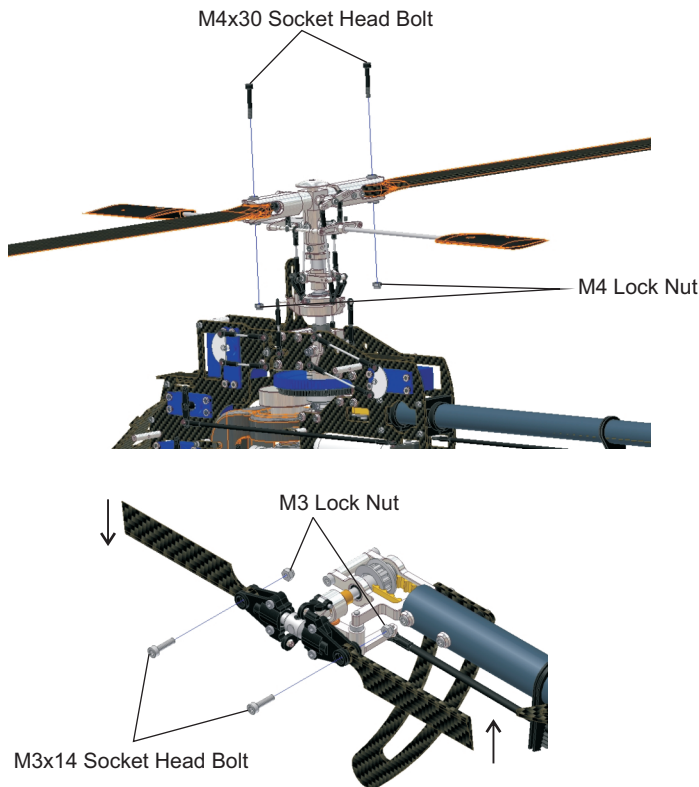

IMPORTANT: Check the correct way you install the tail blades. They should turn counter clock wise looking onto like shown in the diagram above.

STEP 8-1 FINAL SERVO AND RADIO SETUP

Rudder and Throttle Servo Adjustments

1. Checking the servo rotation.

With the radio transmitter and receiver switched on, move the rudder and throttle sticks, and check that each servo moves in the correct direction. If either servo moves in the wrong direction, it will be necessary to reset that servo using the appropriate reversing function on your transmitter.

2. Travel Adjust.

Switch the transmitter and receiver on, then move the rudder and throttle sticks to their extremes and see if each servo moves to its full control position. If either servo moves too far and binds up it will be necessary to reduce the ATV for that channel, likewise if it does not move far enough you will have to increase it. For any given channel, the value in both directions should be equal. Do not exceed a maximum ATV difference of 10%. If the throttle ATV is unbalanced by more than this amount, then the servo sub trim or the positions of the arms on throttle servo and/or on the carburator will have to be repositioned. If the rudder ATV is unbalanced by more than 10% then the servo sub trim and/or tail pitch arm neutral setting should be re-checked and any necessary adjustments made.

NOTE: Try to get the mechanical set up as close possible to the values given in this manual and you will find that final trimming will be so much easier. Using the transmitter to correct a poor mechanical set up will result in a model that is very difficult to trim and fly.

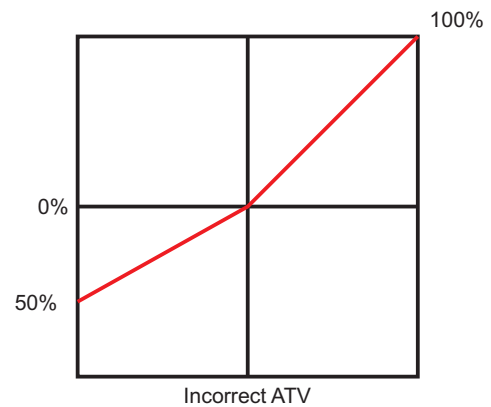
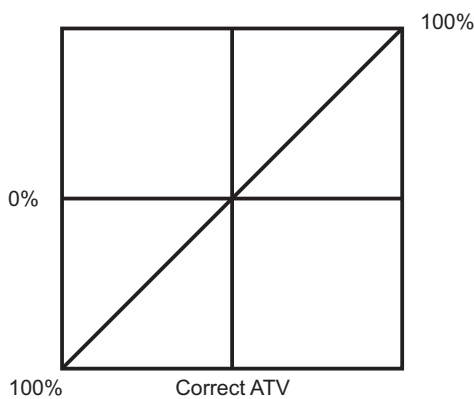

3. Sub trim Function

When the rudder stick and trim are in their mid position make sure that the servo horn and tail control rod are at 90° as shown next. If you cannot achieve the desired servo arm position use the sub trim function to make minor adjustments.

NOTE: It is necessary to keep the sub trim values as close to zero as possible to make final setting up simple.

If you are not using a head locking gyro it will be necessary to adjust the revolution mixing to compensate for the torque changes of the engine during all flight conditions (except autorotation). We recommended that the initial Revo mix values be set to approximately 10% for hovering and 5% for stunt/aerobatic flight. Since there are many variables that can alter the values of the revolution mixing, it will be necessary to fine tune these according to your flying style. If you are using a dual function gyro ie one that can be switched between normal and head locking mode, then please refer to your gyro's instructions for more information.

NOTE: The Revo mixing values must be set for a helicopter with a clockwise rotating head.

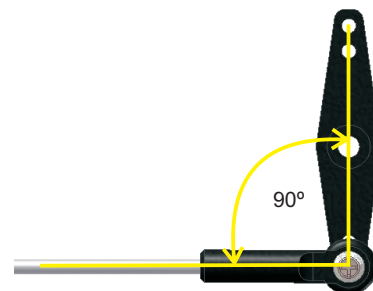
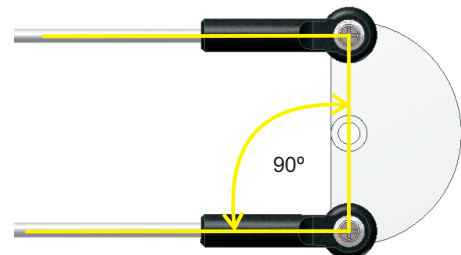

STEP 8-2 FINAL SERVO AND RADIO SETUP

Now that the radio system is fully installed the following items require precise adjustment to achieve the best results.

1. Dual Rates

If dual rates are available for the aileron, elevator and rudder channels, then please ensure that they are all set to the same position for high and low ie. all up or all down. Either switch position may be selected as the low or high rate. Please see your radio manual for further information.

2. Exponential Setting

We suggest that exponential rate settings for the elevator and aileron remain at zero during the initial test flights. When the model has been properly trimmed you may adjust the exponential values to achieve the control feel that suits you. When using a fast response gyro on the rudder the exponential value should be adjusted to approximately 40% to 60% to improve control response and reduce any hunting of the tail.

3. Sub Trim

We suggest that the correct settings be achieved with the minimum use of this function. If the sub trim is used for final adjustments, the values should not vary by more than +/- 10 from the neutral point. If the values need to be greater than this then please reset the sub trim to zero and recheck and/or re-adjust the control linkages.

4. Throttle Hold Function

When this switch is activated, the throttle channel is set to hold the engine to a pre-set idle while still leaving control of the collective pitch active. This is very useful when practicing autorotation landings. It is recommended that the throttle hold value be adjusted to give an idle rpm which is slightly above normal.

5. Gyro Gain Adjustment

The "gain" or holding power of the gyro will have to be set to prevent the tail moving due to changes of wind direction and engine torque. If the gain is too low the helicopter tail will move making it difficult to control. Please refer to your gyro's instructions for the correct set up procedures. Increasing the gain provides more tail stability up to a point when hunting from side to side will occur. We recommended that you start with a gain value of approximately 80% and continue to increase it until the tail of the helicopter starts to Hunt (goes back and forth very quickly). At this point you should reduce the gain a little at a time until the tail becomes stable again. This same adjustment will also be necessary to achieve proper forward flight. Generally, the gyro gain for forward flight will be approximately 10%-20% less than that for hovering, and is due to the aerodynamic forces present in forward flight.

6. Gyro Direction

The gyro direction has to be set correctly. An uncontrollable pirouette will occur on take off if it is not. To set the gyro direction, turn the radio system on and move the rudder stick to the right noting in which direction the servo arm moves. Next, suspend the helicopter by the rotor head, watch the servo arm as you rotate the body of the helicopter counter clockwise. The servo arm should move in the same direction as observed previously. If the arm moves in the opposite direction, reverse the gyro direction and re-test.

NOTE: We recommend that a good quality high-speed servo be used for controlling the tail rotor. Please refer to your gyro's instructions for further information.

STEP 8-3 FINAL SERVO AND RADIO SETUP

7. Collective Pitch Setup.

A Pitch Gauge will be required for this operation

	LOW	MIDDLE	HIGH
NORMAL	-4°	+5.5°	+10°
IDLE UP	-10°	0°	+10°
AUTOROTATION	-14°	0°	+14°

The total pitch range of the *X-TREME 50* is approximately 30 degrees depending the rotor head settings you have done. With a maximum and minimum pitch of +15 and -15 degrees. This means that the center value is 0 degrees. Attach a pitch gauge to one rotor blade and check that the collective pitch setting at centre stick is indeed 0 degrees. If the pitch value is slightly more or less then adjust the length of the connecting rod until the value is correct and then do the same for the other blade.

3D Settings

With the center pitch value set now to 0 degree, it will be necessary to set the maximum positive and negative values to those shown in the tables above. If the values do not correspond try increasing or decreasing the pitch curve, use the swashplate CCPM mixing function on your transmitter, increase or decrease as necessary without causing binding. If you still have difficulty in obtaining the maximum positive or negative pitch values shown in the tables recheck the pitch control rod lengths, and re-adjust as necessary.

8. Pitch Curve

This setting allows you to set the pitch of the main blades to the corresponding position of the collective stick. Adjust the main blades to give the settings shown in the chart below. You may find it necessary to make minor adjustments to these values to suit your particular setup.

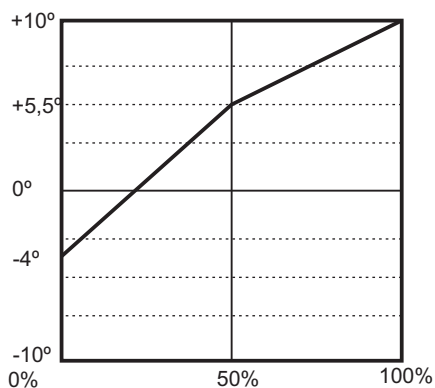

STICK POSITION
NORMAL MODE

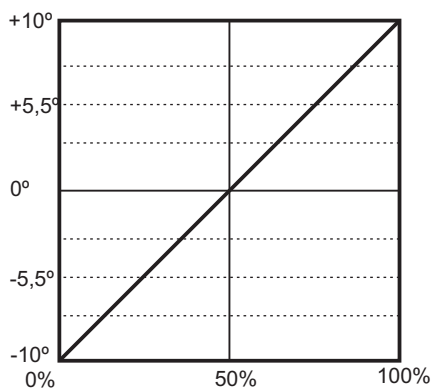

STICK POSITION
IDLE UP

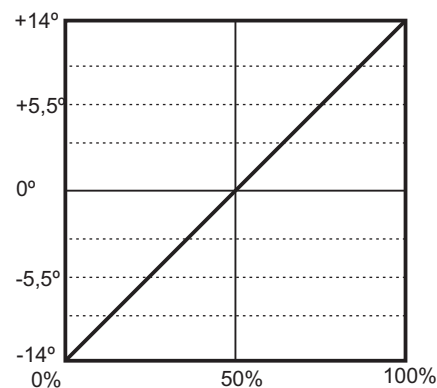

STICK POSITION
AUTOROTATION

STEP 8-4 FINAL SERVO AND RADIO SETUP

9. Throttle Curve

It is very important to match the throttle curves to those of the main blades. Throttle values should be adjusted so that the engine does not over rev when the pitch range is close to zero degrees and the rotor head should not exceed 2,200 rpm under any circumstances. Below are three examples of throttle curves for basic flight conditions.

NOTE: Throttle curves values can vary greatly due to engine and muffler combinations and so it will be necessary to fine tune these settings by test flying to achieve the best results.

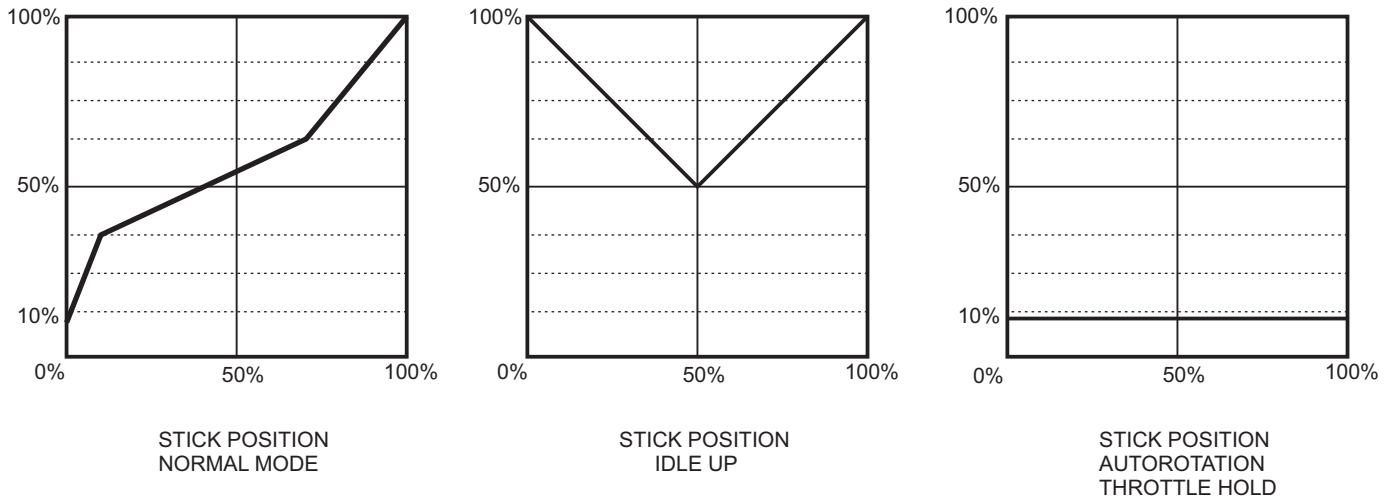

10. Engine Adjustment

For optimum results it is important that the engine is set up to run properly, and since this depends on the setting of the mixture needle, the best position should be obtained by running the engine on the bench if possible. If you are using a brand-new engine, please refer to the manufacturer's instructions for the break-in procedure.

NOTE: For the first flights always run the engine a little rich and adjust for optimal performance as you progress. Remember, a lean engine is a dead engine.

11. Final Checks before attempting to flights

Before attempting to fly please go through this manual and double check your work again.

Check that the main and tail rotor blades turn in the correct direction.

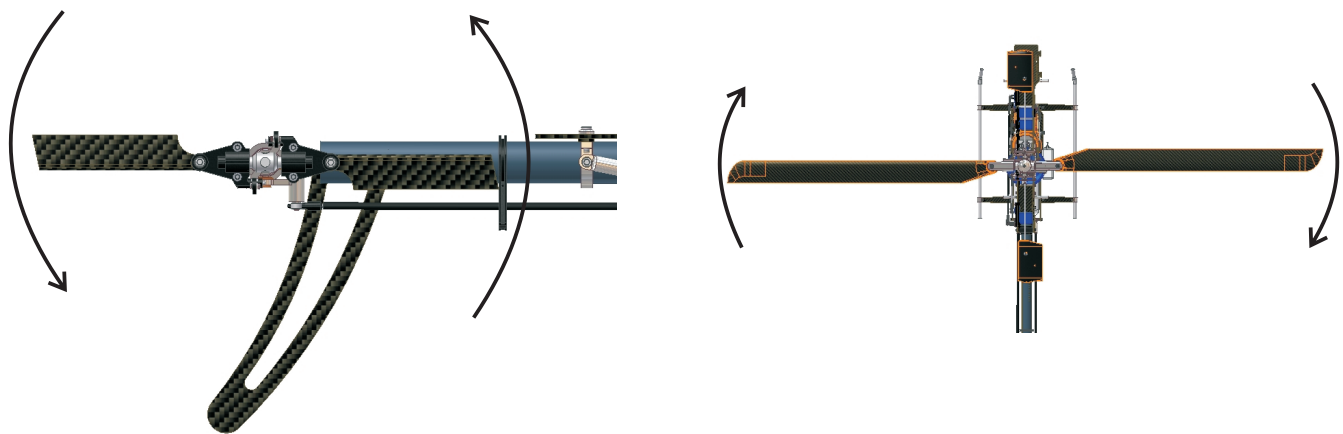

- Check to ensure that all of the servos are operating smoothly and in the correct direction and that each servo horn is secured with a screw.
- Ensure that the throttle servo is working properly and in the correct direction.
- Check that the gyro is operational and compensating in the correct direction.
- Make sure that both the transmitter and receiver have been fully charged.
- Check that the main and tail rotor blades are installed correctly.
- You are now ready for your first flight with the X-TREME 50 and your next step is the adjustment of your engine. Since this depends on the fuel, plug and weather conditions we suggest that you seek help from an experienced helicopter pilot if possible.

STEP 8-5 FINAL SERVO AND RADIO SETUP

Caution: Be sure to maintain a safe distance of at least 5 meters from the helicopter when observing the track of the main rotor disc.

Blade tracking ensures that both of the main blades are set to the same pitch angle, and if done correctly will make your helicopter smooth in operation.



Caution: Be sure to maintain a safe distance of at least 5 meters from the helicopter when observing the tracking of the main rotor disc.

Adjustment should be done using the following method.

Increase the pitch of the low blade by extending its connecting link by one full turn. Note you can only make this adjustment in increments of one full turn otherwise you will be trying to fit the link on to the ball joint the wrong way round. (The "RJX" on the link must face outwards). Check the tracking again and if the tips of the rotor blades are now in line, you have finished and are ready for your first flight. If the blades still require adjustment then reduce the pitch of the high blade this time. Repeat this procedure until the blades are tracking true.

A check of the tracking should be part of your pre-flight routine. If it has suddenly gone out it is an indication that something is wrong and needs immediate investigation.

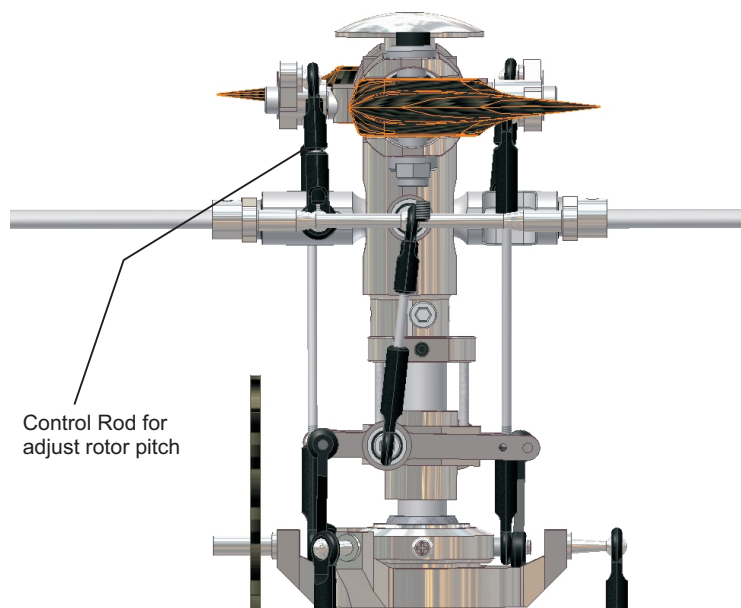

PLEASE READ BEFORE FLIGHT

The **X^{TREME} 50** is the perfect choice for intermediate and expert level R/C Helicopter pilots, however, Radio controlled models such as this can crash and cause serious damage to people and property if not properly assembled and flown with great care. Please exercise the highest levels of caution and safety when operating this model and if you are a beginner, please seek help from an experienced RC heli pilot.

Pre-Flight

Check the battery voltages of the transmitter and receiver packs. Do not risk that “last flight”, it really might be the last.

Check to ensure the main rotor and the tail rotor are free from damage. Do not fly with suspect components. Range check the transmitter to a distance of at least 60–75 meter from the model with the transmitter antenna down, checking all control movements.

After filling the tank with fuel, make sure that there is no leakage.

Ensure that the throttle stick is at idle and always hold the rotorhead firmly before attempting to start the engine. Throttle hold should be switched on to make sure that the engine does not respond to accidental movements of the throttle stick, especially when carrying the model to the launch pad.

When Flying.

Do not fly your **X^{TREME} 50** near to any houses, high voltage wires or busy roads.

Be sure to fly within the range of your radio.

Always keep your eyes on your model when flying, it can change attitude or get out of sight in a very short time.

Never hover with the rotor at eye level. Be sure to keep the model at a safe height and altitude.

If you feel that something is wrong with your model while flying, land it immediately and check it over. Do not take any chances.

After Flight

When the rotor speed has slowed sufficiently, use the palm of your hand on the head button to bring it to a stop. Check to ensure that nothing has come loose.

If the main rotor or other parts have made contact with the ground do not take any chances. Replace them before the next flight even they look to be in good condition.

Make sure the receiver, battery and gyro are still secure.

Make a periodical check of the Helicopter to make sure there is no damage or loose screws. Also check fuel tubing in both tank's. Check all bearings to ensure they are working smooth, they can cause glitches if they are damaged.

SPARE PART LIST

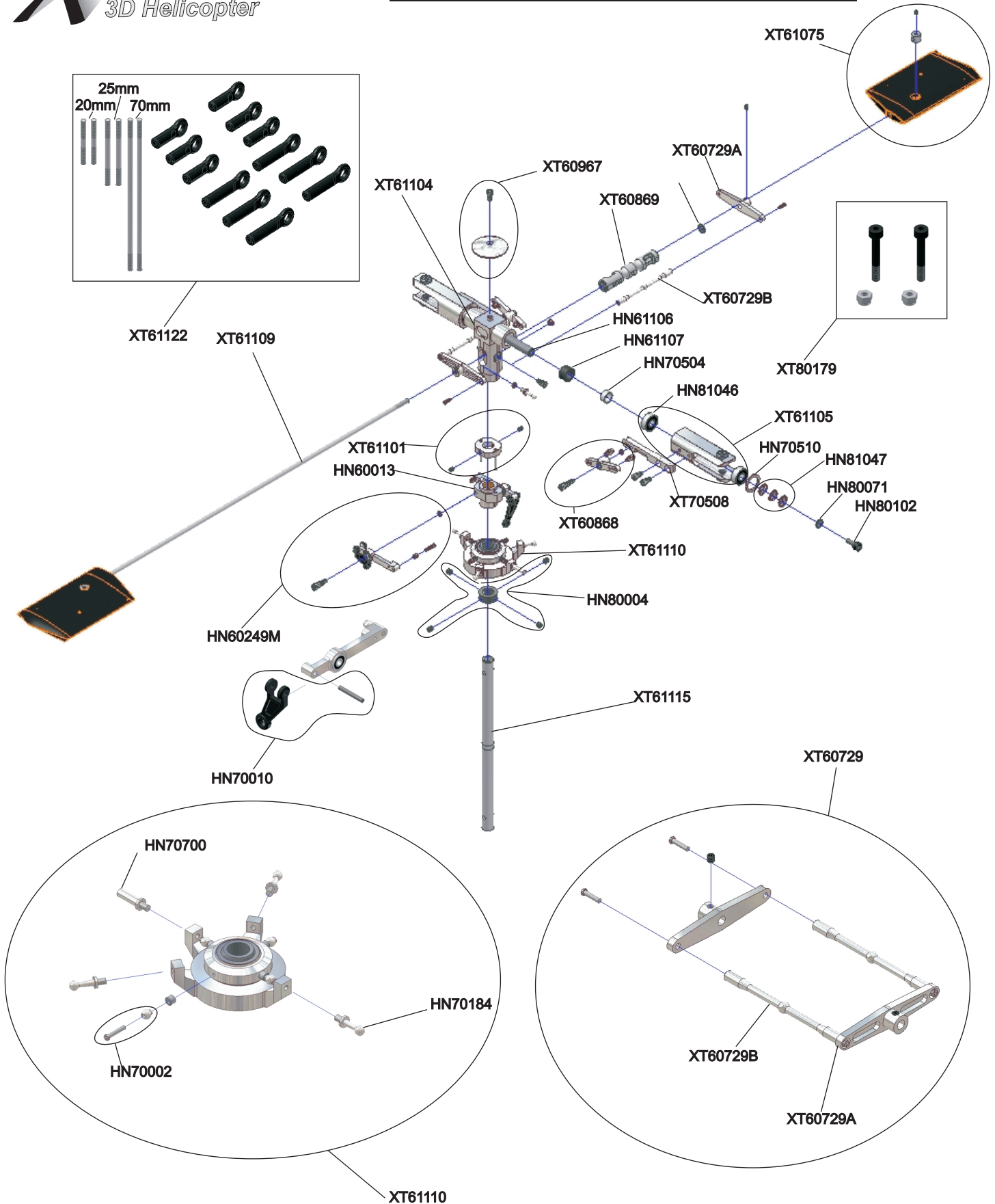

SOME OF THE LISTED SPARE PARTS ARE NOT SOLD SEPERATLY

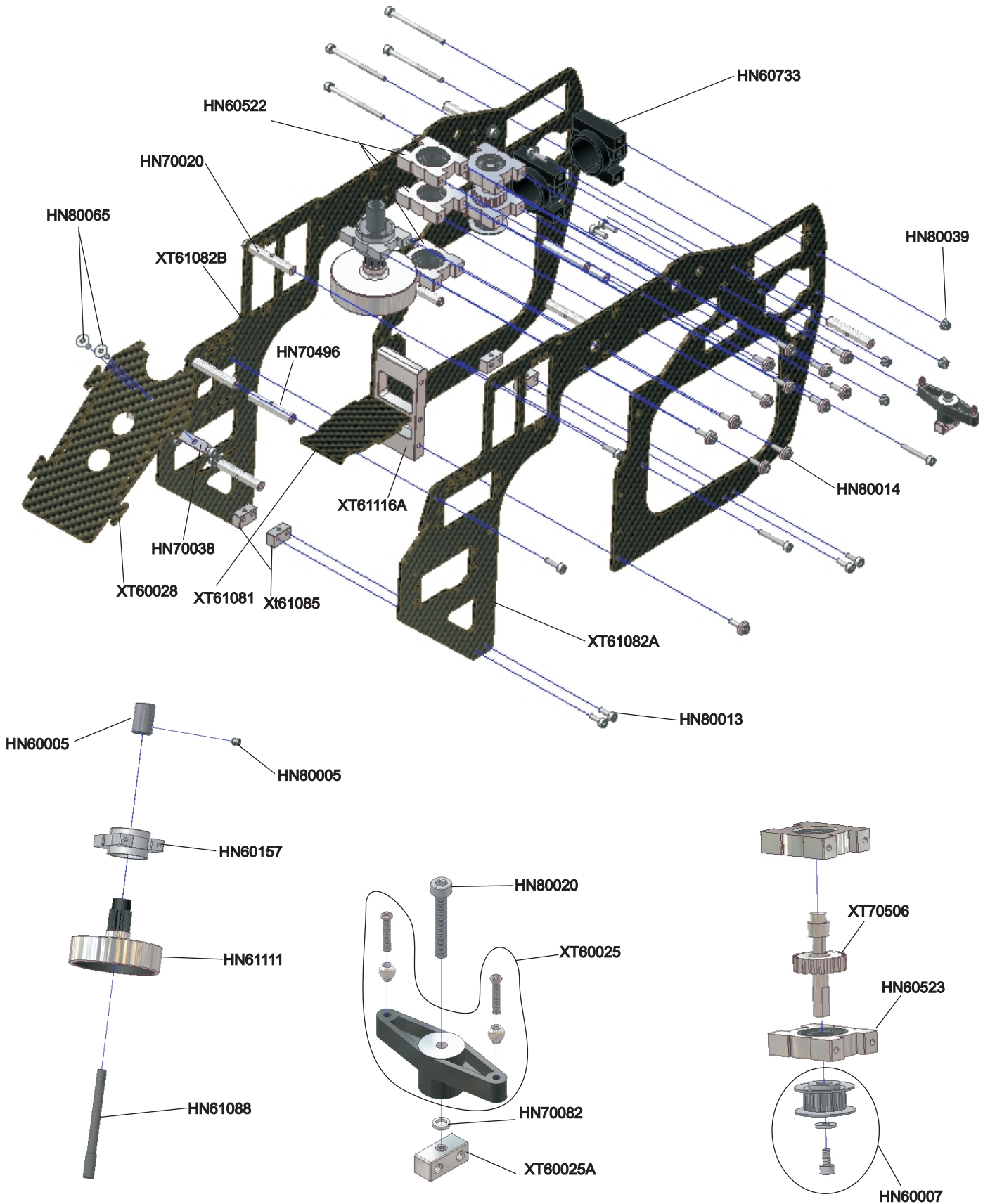

SOME OF THE LISTED SPARE PARTS ARE NOT SOLD SEPERATLY

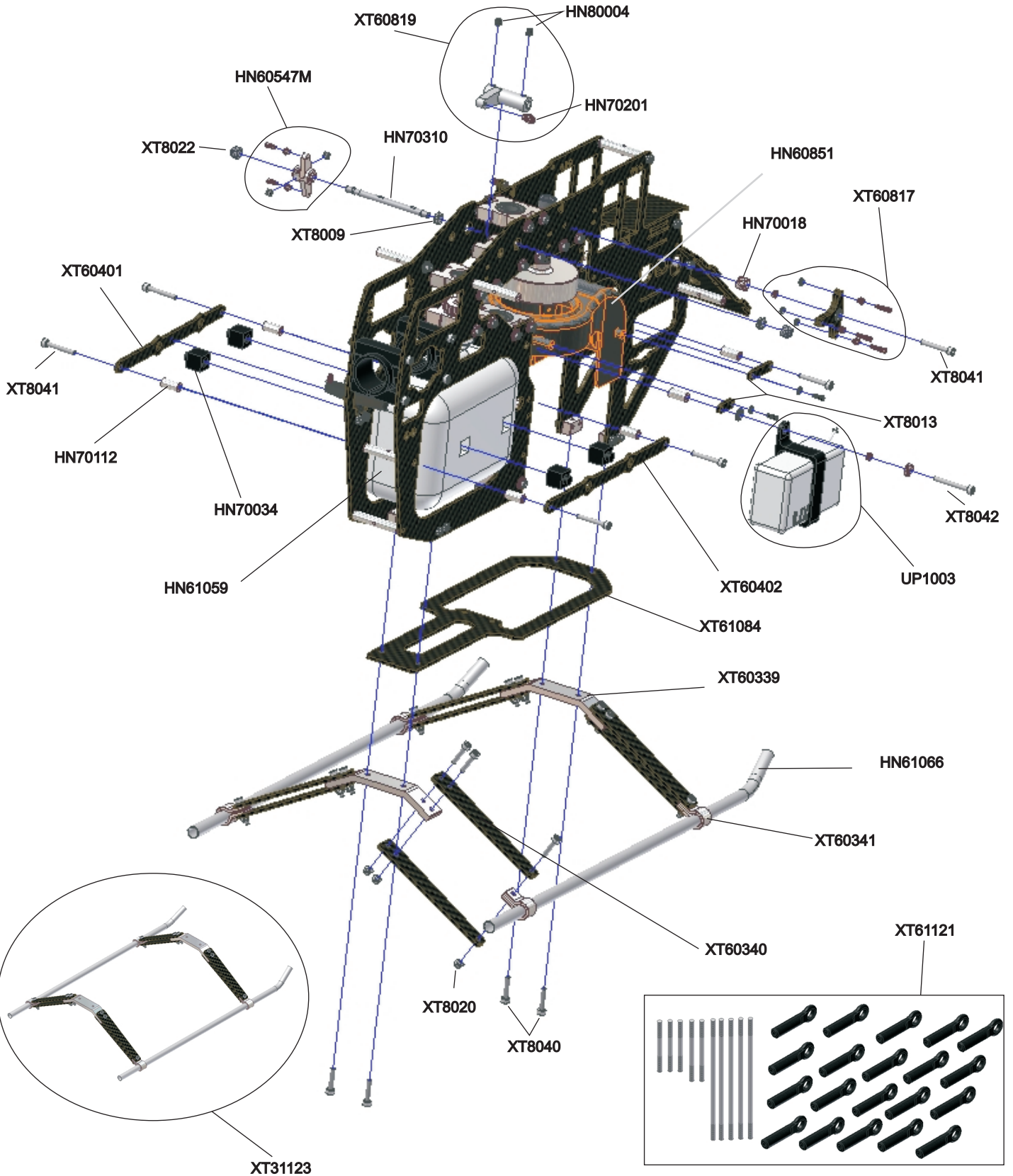

SOME OF THE LISTED SPARE PARTS ARE NOT SOLD SEPERATLY

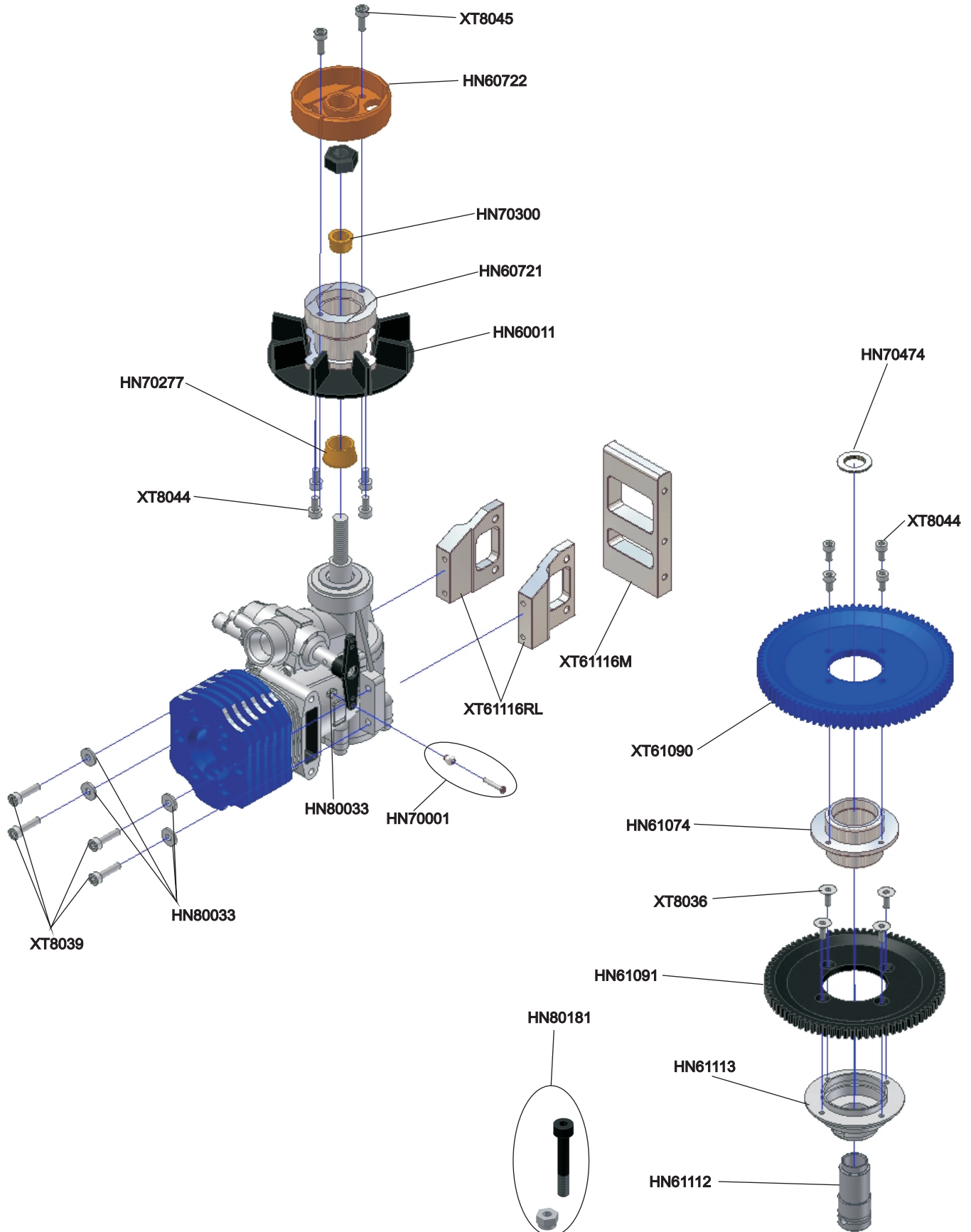

SOME OF THE LISTED SPARE PARTS ARE NOT SOLD SEPERATLY

SPARE PART LIST

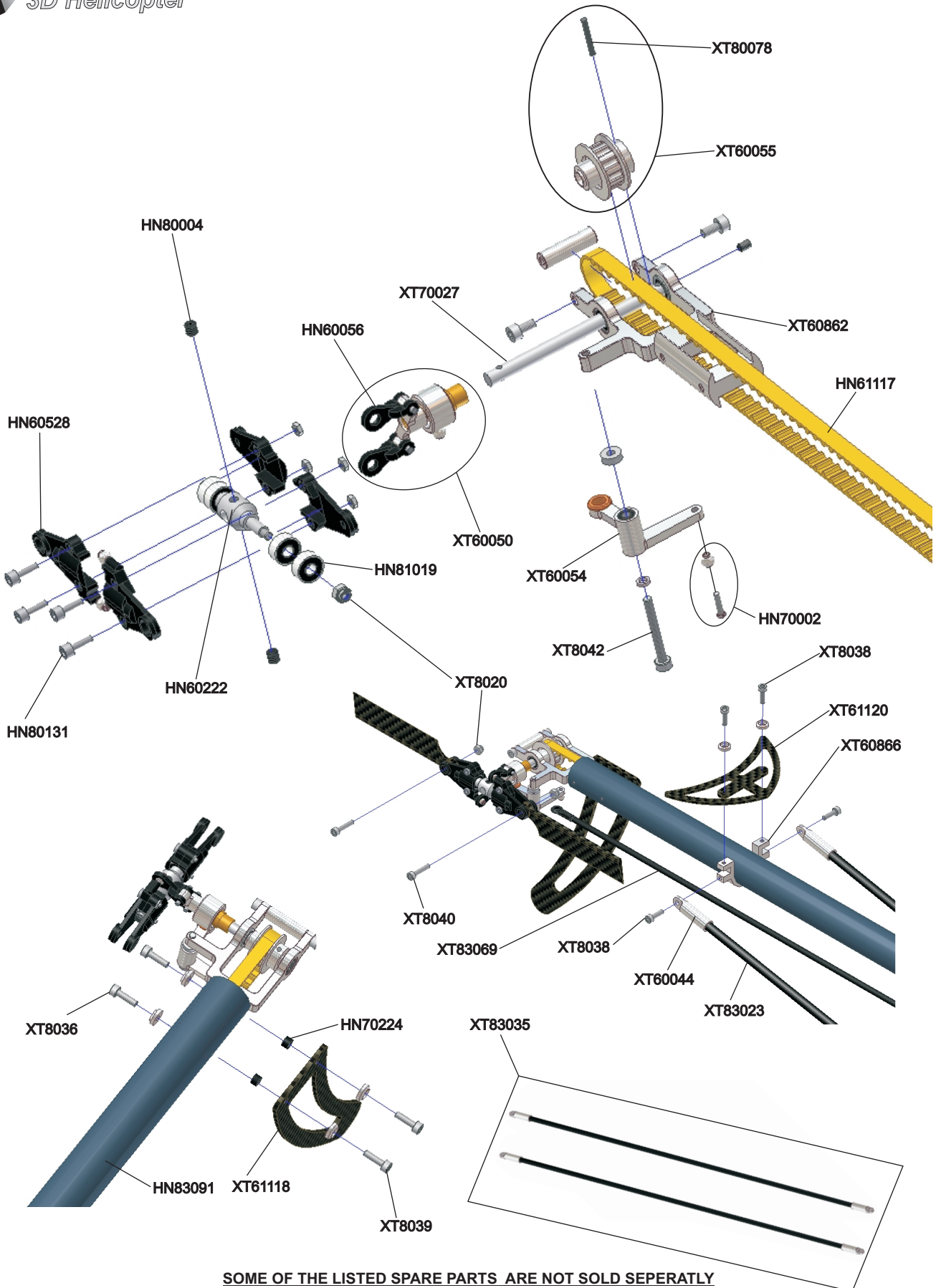

SOME OF THE LISTED SPARE PARTS ARE NOT SOLD SEPERATLY

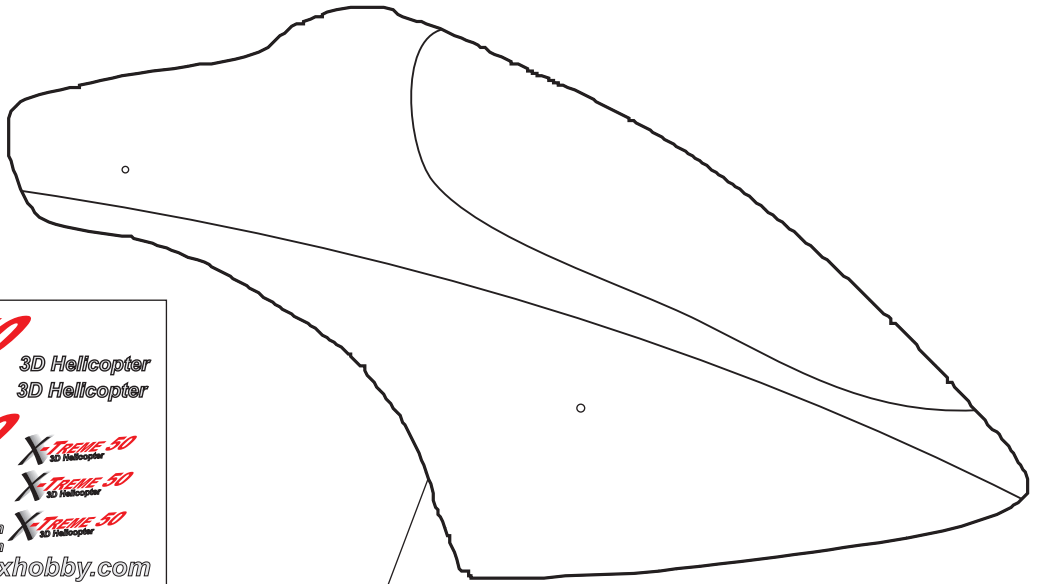

XT0001

XT82276Y = Yellow
XT82276O = Orange

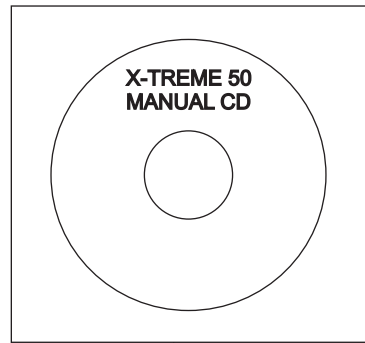

XT0002